

SCB



Operating Instruction



Safety Time Control Device SCB

H. Zander GmbH & Co. KG
Am Gut Wolf 15
52070 Aachen, Germany
info@zander-aachen.de
www.zander-aachen.de

Number: E61-049-00
Version: N06a
Ver. B

Engl. Translation of the original
document

Subject to technical modifications,
no responsibility is accepted for
the accuracy of this information.

Contents

1. Scope	5
1.2 Additional documents	5
2. Target group	5
3. Safety instructions	5
4. Appropriate use	6
5. Disclaimer and warranty	7
6. Features	8
7. Functions	9
7.1 Functions of the safety circuit I21-I11 and I22-I12	9
7.2 Functions of the reset circuit X1	9
7.3 Functions of the feedback loop Y1	9
7.4 Functions of the safe semiconductor output P1 and O2	10
7.5 Functions of the safe relay contact 17-18 and 27-28	10
7.6 Functions of the auxiliary outputs C1 and C2	10
7.7 Functions of the delay time	10
8. Application example	11
8.1 Functions of the safety circuit I21-I11 and I22-I12	11
8.2 Functions of the reset circuit X1	12
9. Mounting	14
10. Electrical connection	15
11. Checks, maintenance and Proof-Test	16
11.1 Checks and maintenance	16
11.2 Proof-Test	16
12. Wiring	17
12.1 Wiring reset circuit	17
12.2 Wiring feedback circuit	17
12.3 Wiring safety circuit	17
12.4 Wiring supply voltage	18
12.5 Wiring safe relay contacts and safe semiconductor oututs	18
12.6 Wiring auxiliary outputs	18

13. Configuration of the SCB	19
13.1 Loading a configuration	19
13.2 Parametrization of a delay time	21
14. Commissioning procedure	23
15. Diagnostic functions	24
15.1 Operating state wir Off-delay outputs/contacts	24
15.2 Operating state wir On-delay outputs/contacts	25
15.3 Configuration display	26
15.4 Error monitoring	27
15.5 Error memory	28
16. Configurations tables	29
16.1 Configuration table for variants SCB-04, SCB-04m, SCB-04h	29
16.2 Configuration table for variants SCB-04-01, SCB-04m-01, SCB-04h-01	29
16.3 Configuration table for variants SCB-03, SCB-03m, SCB-03h	30
16.4 Configuration table for variants SCB-03-01, SCB-03m-01, SCB-03h-01	30
16.5 Configuration table for variants SCB-02, SCB-02m, SCB-02h	31
16.6 Configuration table for variants SCB-02-01, SCB-02m-01, SCB-02h-01	31
17. Timing diagrams	32
17.1 Timing diagram SCB-04 with Configuration Pr04	32
17.2 Timing diagram SCB-04 with Configuration Pr19	33
17.3 Timing diagram SCB-04-01 with Configuration Pr24	34
17.4 Timing diagram SCB-04 with configuration Pr28	35
17.5 Timing diagram SCB-04-01 with Configuration Pr27	36
18. Dimensions	37
19. Safety parameters	38
20. Technical data	39
21. Derating	41
22. Variants	42
23. Declaration of Conformity	45

1. Scope

1.1 Validity

This document is valid for:

Type	Order-No. Plug-in screw terminals	Order-No. Plug-in spring-cage terminals
SCB-04	474460	475460
SCB-03	474480	475480
SCB-02	474490	475490
SCB-04m	474461	475461
SCB-03m	474481	475481
SCB-02m	474491	475491
SCB-04h	474462	475462
SCB-03h	474482	475482
SCB-02h	474492	475492
SCB-04-01	474465	475465
SCB-03-01	474485	475485
SCB-02-01	474495	475495
SCB-04m-01	474466	475466
SCB-03m-01	474486	475486
SCB-02m-01	474496	475496
SCB-04h-01	474467	475467
SCB-03h-01	474487	475487
SCB-02h-01	474497	475497

1.2 Additional documents

Title	Content	Remark
Beipack	Brief instruction	Supplied with the product

2. Target group

Specialist electricians and assembly, setup and service specialists who possess special knowledge in working with safety components.

3. Safety instructions



Safety components are intended to protect people. Not following the safety instructions, improper installation or manipulation may result in fatal injuries to persons and damage to property. Safety devices must not be bypassed, removed or manipulated in any way. Please follow all the safety instructions and warnings mentioned in this document.

- Installation, commissioning, maintenance, and decommissioning should be done only by authorised and qualified technicians:
 - who are familiar with proper handling of the safety components
 - who are familiar with the applicable EMC and ESD regulations
 - who are familiar with the local regulations concerning work safety and accident prevention
 - who have read and understood these operating instructions.
- Opening the device, any kind of manipulation to it and bypassing the safety devices are not permitted
- The electrical connection of the device must take place only when the voltage supply is switched off
- Loads at the outputs must be disconnected from the device during device configuration
- The wiring of the device must be according to the instructions of this user information, otherwise there is a risk that the safety function will be lost
- The current paths 17-18 and 27-28 must carry only the same voltage potentials
- The device version (see nameplate "Ver.") should be stored and checked before every commissioning. When there is a version change, the use of the device in the overall application should be revalidated

4. Appropriate use

The SCB is a universally applicable safety time control device, with which the moving parts of a machine or plant can be brought to a standstill quickly and safely in case of danger. Depending upon the configuration, the safety outputs connect on-delay, off-delay or without delay independent of one another.

The approved operating parameters for use must be complied (see "Technical data").

A risk assessment should be carried out on the machine before using the device. For example, according to:

EN ISO 13849-1, Safety-related parts of control systems, Appendix A

EN ISO 12100, Safety of machinery - General principals for design - Risk assessment and risk reduction

IEC 62061, Safety of machinery - Functional safety of safety-related electrical, electronic and programmable electronic control systems.

Additional requirements may have to be considered depending on the type of machine or plant.

Appropriate use also includes compliance with:

EN ISO 13849-1, Safety-related parts of controllers,

EN 60204-1, Electrical equipment in machines.

For further information please refer to the above mentioned documents.



ATTENTION!

The user is responsible for integrating the device into a safe overall system. For this purpose, the overall system has to be validated, e.g. according to EN ISO 13849-2.

If a operating instruction is enclosed with the product, then the specifications given in the operating instruction are applicable

5. Disclaimer and warranty

If the above mentioned conditions for appropriate use are not complied with or if the safety instructions are not followed or if any maintenance operations are not carried out as required, this shall lead to an exclusion of liability and loss of warranty.



ATTENTION!

We would like to point out that it is the full responsibility of the operator to ensure a plant availability.

Using the SCB, a safety emergency stop relay according to

- EN ISO 13849-1
- IEC 62061
- IEC 61508
- EN 50156-1
- EN 746-2
- IEC 61511-1

is used, which will be brought into the safe state when the safety function is requested.

This means that the connected load is switched off as soon as a request from connected sensor elements or diagnostic measures detects a dangerous state, e.g. caused by a component fault.

Since process-related applications in particular have high demands on availability, limited availability can also have significant consequences.

It is therefore recommended to stock a second unit to avoid long downtimes in such a case.

These are recommendations of the manufacturer, the evaluation of the importance of the plant availability is the sole responsibility of the operator.

6. Features

- Depending on variant:
 - 2 safety semiconductor outputs and 2 safety relay contacts (SCB-04)
 - 2 safety relay contacts (SCB-02)
 - 3 safety semiconductor outputs (SCB-03)
- Switching behaviour configurable on the device
- 2 semiconductor auxiliary outputs
- Adjustable switch-on / switch-off delaytime
 - Depending on variant: 0 to 99 s; 0 to 99 min; 0 to 99 h (Resolution ≥ 0.1 s/min/h)
- Connection of:
 - Potential-free NC contacts
 - PNP-Semiconductor outputs
 - OSSD outputs
- Single or dual-channel operation possible
- Simple, fast and accurate delaytime adjustment via push/rotary button and display
- Indication of all switching states via LED
- Automatic or monitored, manual reset
- For safety applications up to PL e, Cat. 4, SIL 3
- For furnaces in continuous operation according to EN 50156-1 and EN 746-2
- EN ISO 13849-1; IEC 62061; IEC 61508; IEC 61511; EN 50156-1; EN 746-2

7. Functions

The safety time control device SCB is conceptualised for the safe isolation of safety circuits according to EN 60204-1 and can be used in safety applications up to, PL e, Cat. 4, SIL 3 as well as on furnaces in continuous operation according to EN 50156-1 and EN 746-2. Figure1 shows the block diagram of the SCB.

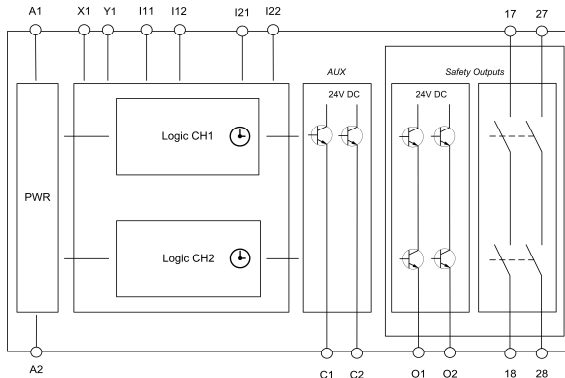

Figure1: Block diagram SCB

7.1 Functions of the safety circuit I21-I11 and I22-I12

Depending on the wiring, the input circuits I21-I11 and I22-I12 are used for two-channel or single-channel control and thus monitoring of connected sensors.

7.2 Functions of the reset circuit X1

The reset behaviour of the SCB is determined via terminal X1 in combination with the selected configuration. Automatic and monitored manual reset are available.

7.3 Functions of the feedback circuit Y1

If contactors or expansion modules are controlled via the SCB, they can be monitored via a feedback circuit to terminal Y1. This prevents a restart in the event of a contactor failing in a dangerous state.

7.4 Functions of the safe semiconductor outputs O1 and O2

Taking into account the selected configuration, the safe PNP semiconductor outputs switch on when the safety circuit is closed. Opening the safety circuit leads to a switch-off.

7.5 Functions of the safe relay contacts 17-28 and 27-28

Taking into account the selected configuration, the safe relay contacts switch on when the safety circuit is closed. Opening the safety circuit leads to a switch-off.

7.6 Functions of the auxiliary outputs C1 and C2

Two semiconductor outputs C1 and C2 are available for signalling different states. The switching behaviour is determined by the selected configuration.



ATTENTION!

Auxiliary outputs must not be used as safe outputs.

7.7 Functions of the delay time

Depending on the configuration, the safe output/contacts can switch on or off time delayed to the safety circuit. The following time functions can be configured:

- **Switch-On delay**

The safe outputs/contact will switch-on time delayed if the safety circuit ist getting closed and a proper reset signal occurs. Opening the safety circuit leads to an immediate switch-off of the safe outputs/contacts.

- **Switch-Off delay**

The safe outputs/contact will switch-on immediate if the safety circuit ist getting closed and a proper reset signal occurs. Opening the safety circuit leads to time delayed switch-off of the safe outputs/contacts.

- **Wiping function**

Taking into account a proper start command, the safe relay contacts are activated with the closing of the safety circuit and switch off again after the set delay time has elapsed. Opening the safety circuit before the delay time has elapsed results in immediate switch-off. A renewed switching of the relay contacts is only released by opening and re-closing the safety circuit.

- **Switch-Off delay with automatic Re-Trigger function**

In the event of a switch-off delay with automatic re-trigger function, the safe outputs/contacts switch on immediately by closing the safety circuit and a monitored, manual reset command. If the safety circuit is opened, the outputs/contacts are switched off immediately or with a time delay according to the selected configuration.

If the safety circuit is closed again before the countdown of the parametrized delay time is ended, the outputs/contacts that have already been switched off are automatically activated again. For the still activated outputs/contacts, the countdown of the delay time is stopped and reset for the next request.



ATTENTION

If the function switch-off delay with automatic re-trigger function is used, the automatic reset at the moment of re-triggering has to be considered separately, since the monitored, manual start is disabled in this moment.

8. Application example

8.1 Filtering exceedings of set limit values with automatic re-trigger function

Short-term, process-related exceeding of set limit values cannot be completely excluded, and should not necessarily lead to the immediate shutdown of a system.

Because this might lead to unnecessary standstills with a high personnel expenditure regarding resetting.

By filtering these signals with an SCB, the availability of a system can be maintained without safety loss. Figure 2 shows a suitable application example with an SCB-02.

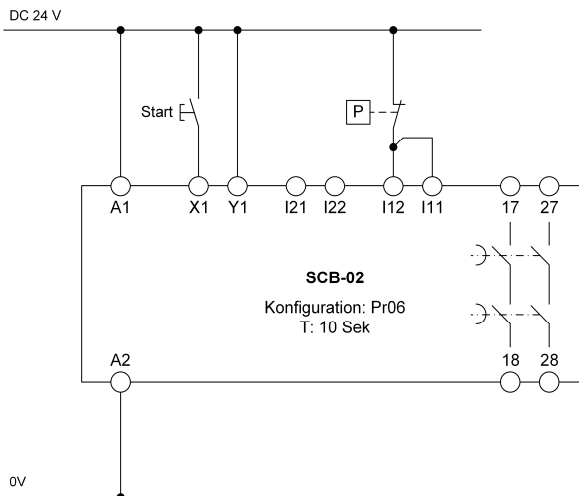

Figure 2: SCB-02 for filtering short-term triggering of a pressure switch

With the selected configuration Pr06, which allows a monitored, manual start with automatic re-trigger function as well as a time-delayed switch-off of the safe relay contacts, the SCB-02 filters a short-time triggering of the connected pressure-switch up to 10 seconds.

If an overpressure is detected, the time delay at the SCB-02 is triggered. This means that the safe relay contacts remain closed for a period of 10 seconds.

If the pressure falls below the limit value within this time an automatic re-triggering of the SCB-02 takes place. This means that the running time delay is stopped and the relay contacts remain energized.

However, if an overpressure persists after the 10 seconds, the SCB-02 switches off its safe relay contacts. A restart is only possible again after acknowledgement via the reset-button.

8.2 Time delayed reset

Accidental resetting of a safety system can lead to a hazard if a person is in the danger zone at this time.

By using an SCB-04 with configuration Pr27 ("delayed reset") in combination with a safety relay (e.g. SR3C) this can be prevented.

For this, two reset buttons are used to release a machine located in the danger zone. In combination with the SCB-04 and two safety relays, the safety guard door, the sequence as well as the time window for actuating the reset buttons are monitored (see Figure 3 and Figure 4).

Reset button 1 is mounted in the danger area and reset button 2 in the safe area. Both in such a way that the operating personnel have a clear overview of the danger area.

By pressing the RESET1 button, the safety circuit for the safety relay K2 is enabled for the parameterised time window of 20 seconds. This is completely closed as soon as the operator leaves the danger zone through the safety door and closes it.

Now the machine can be released within the remaining time via the RESET 2 button. By guiding the safety circuit of K2 via its own relay contacts, K2 remains in self-retaining mode after release via RESET 2.

If the time running on the SCB-04 has elapsed before pressing the RESET 2 button, the safety circuit of K2 is blocked again and disconnection of the machine is prevented.

Without actuating the RESET 1 button in the danger area, the machine cannot be released even with the safety door closed.

An accidental start of the machine without the knowledge of a person in the danger area is thus safely prevented.

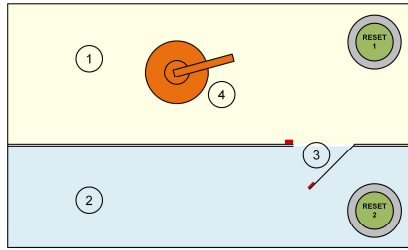

- ① Gefahrenbereich
- ② Sicherer Bereich
- ③ Schutztür mit Überwachung
- ④ Maschine

Figure 3: Application example - Time delay reset with two reset buttons

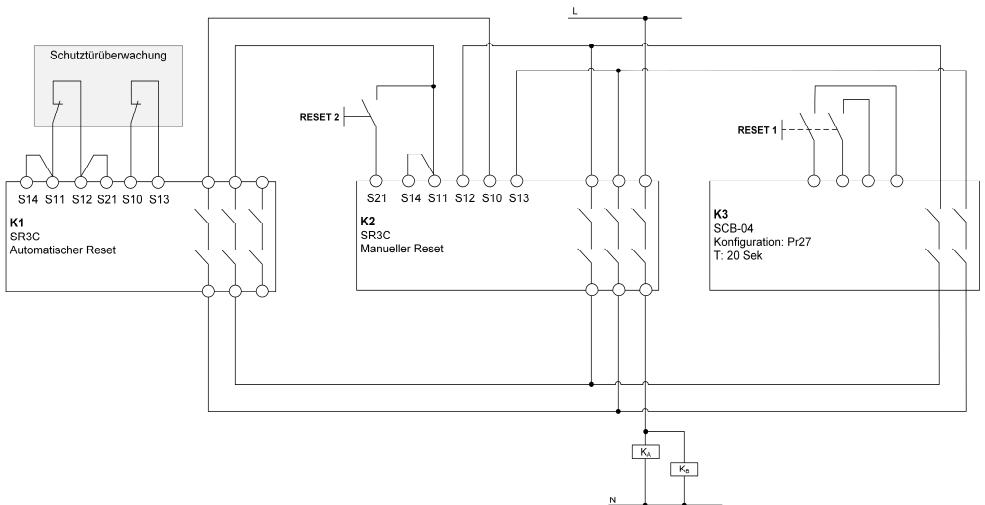

Figure 4: Wiring example für application example - Time delayed reset

9. Mounting

The device has to be installed in a cabinet having minimum protection class of IP54:

- Mount on a 35 mm mounting rail as per EN 60715
- For optimum heat dissipation, mount with ventilation slots facing upwards
- Ensure adequate heat dissipation in the cabinet
- Mounting distance to neighbouring devices to be maintained is 10 mm

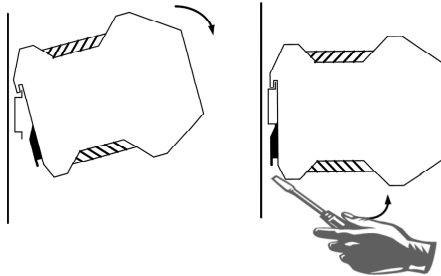

Figure 5: Mounting / Demounting

10. Electrical connection

- Wiring only be carried out while the voltage supply is switched off
- Do not connect any external voltages to the outputs O1, O2, C1 and C2
- The outputs O1, O⁺, C1 and C2 are short-circuit-protected. Overloading is not allowed and results in damage to the device (see „Technical data“)
- Auxiliary outputs C1, C2 may not be used as safety outputs
- A safety transformer according to EN 61558-2-6 or a power supply unit with galvanic isolation should be connected upstream of the mains
- An external fuse for the relay contacts (6 A gG) must be provided
- Inductive loads at the outputs and contacts must have sufficient protective circuitry, e.g. a free-wheeling diode



ATTENTION!

If automatic reset is configured, the SCB is immediately activated when the safety circuit is closed.

The monitored manual reset of the device should not be used to start the machine in accordance with EN ISO 13849-1.

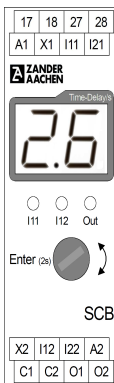

A1:	<i>Power supply (DC 24 V)</i>
A2 :	<i>Power supply (0V)</i>
I11/I21:	<i>Safety circuit channel 1</i>
I12/I22:	<i>Safety circuit channel 2</i>
X1:	<i>Automatic or manual reset</i>
Y1:	<i>Feedback circuit</i>
17-18/27-28:	<i>Safety relay contacts</i>
O1/O2:	<i>Safety semiconductor outputs</i>
C1:	<i>Auxiliary output 1</i>
C2:	<i>Auxiliary output 2</i>

Figure 6: Front view of the SCB - Terminal explanation (for the SCB-04)

11. Checks, maintenance and Proof-Test

11.1 Checks and maintenance

The following checks are regularly required to ensure proper and continuous functioning:

- Check the switching function
- Check for signs of manipulation and safety function bypassing
- Check if the device is mounted and connected securely
- Check for soiling

Check if the safe function of the whole safety system is working properly, in particular:

- Every time after initial commissioning
- Every time after replacing a component
- After a long downtime
- After every fault

Regardless of this, the safe functioning of the safety device should be checked at suitable intervals, e.g. as part of the maintenance schedule of the plant. No maintenance is required for the device itself.

11.2 Proof-Test

To check the correct function of the device within the framework of a proof test, the following steps must be carried out:

Demand the safety function by opening the safety circuit. Check that the safe relay contact 17-18/27-28 and safe semiconductor outputs O1 and O2 are switched off. Check for correct delay time, too.

Close the safety circuit and start the device again. Check that the safe relay contacts 17-18/27-28 and safe semiconductor outputs O1 and O2 are switched on. Check for correct delay time, too.

If the device doesn't switch on again, the proof-test failed.

ATTENTION!



If the proof test was not passed or if the device was damaged, e.g. after an error, faultless operation can no longer be guaranteed. In this case, replace the device. Repairs on the device as well as the opening of the housing may only be carried out by the manufacturer.

12. Wiring

Depending on application or result of the risk assessment, e.g. according to EN ISO 13849-1, the device should be wired according to Figure 7 to 17.

12.1 Wiring reset circuit

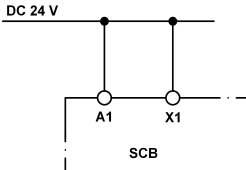

Figure 7:
Automatic reset
Caution:
Safety contacts switch on immediately in the operating state.

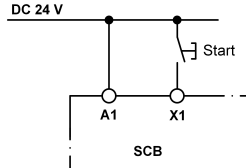

Figure 8:
Monitored manual reset. The reset release is triggered by a falling edge at X1, with which a complete switching operation of the reset button is monitored.

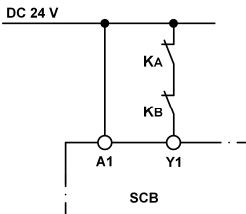

Figure 9:
Feedback circuit.
Monitoring of externally connected contactors or expansion modules. If the feedback circuit is not used, the contact Y1 should be wired to DC 24 V.

12.2 Wiring feedback circuit

12.3 Wiring safety circuit

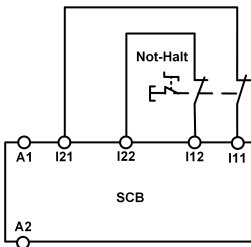

Figure 10:
Dual-channel emergency stop circuit with cross circuit and earth contact monitoring.
For safety applications up to PL e, Cat. 4, SIL 3.

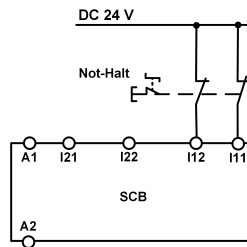

Figure 11:
Dual-channel emergency stop circuit with earth contact monitoring.
For safety applications up to PL d, Cat. 3, SIL 2

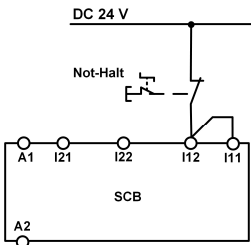

Figure 12:
Single-channel emergency stop circuit with earth contact monitoring.
For safety applications up to PL c, Cat. 1, SIL 1.

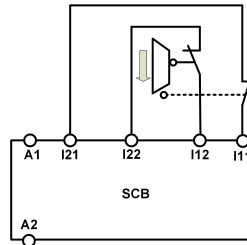

Figure 13:
Dual-channel sliding guard monitoring with cross circuit and earth contact monitoring.
For safety applications up to PL e, Cat. 4, SIL 3.

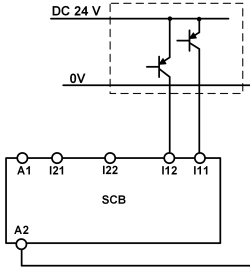

Figure 14:
Dual-channel emergency stop circuit with PNP semiconductor outputs / OSSD outputs with seüerate cross circuit detection. For safety applications up to PL e, Cat. 4, SIL 3.

12.4 Wiring supply voltage

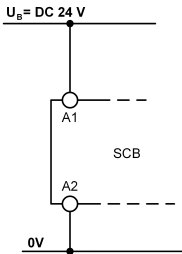

Figure 15:
Connection of the power supply to the terminals A1 and A2.

12.5 Wiring safe relay contacts and safe semiconductor outputs

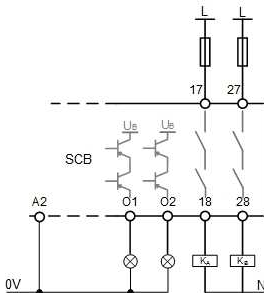

Figure 16:
Connection to switching loads at safety contacts (Exemplary contact configuration. Differing according to device type. Switching voltage "L" according to tech. data).

Inductive loads at the outputs and contacts must have sufficient protective circuitry, e.g. a free-wheeling diode.

12.6 Wiring auxiliary outputs

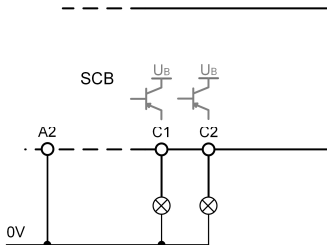

Figure 17:
Wiring auxiliary outputs C1 and C2.

13. Configuration of the SCB

The SCB is delivered with the default configuration "Pr00". With this configuration, the device evaluates the safety circuit and the reset circuit according to the configuration table. However, no delay time is executed. A parameterization of the delay time is therefore not possible. Carry out the following steps when commissioning the device for the first time. Table 1 explains the symbols used for this purpose.



Symbol	Description
	Press the push/rotary button for minimum 2 seconds.
	Press push/rotary button briefly
	Turn push/rotary button
2 s	Wait for 2 seconds

Table 1: Symbol explanations

13.1 Loading a configuration

ATTENTION: Make sure that during the loading of the new configuration the supply voltage of the the unit's power supply is securely connected. A power-off during the charging process will result in a non-acknowledgeable error condition.

Determine the desired configuration number using the configuration table shown in Chapter 16. By entering a PUK (**P**arametrization **U**nblocking **K**ey) you reach the configuration selection (PUK for loading a configuration: **6 - 1**).

To do this, switch on the supply voltage while pressing the push/rotary button at the same time. A running light as well as the following display "Pu" informs about the menu item PUK (see Figure 18).

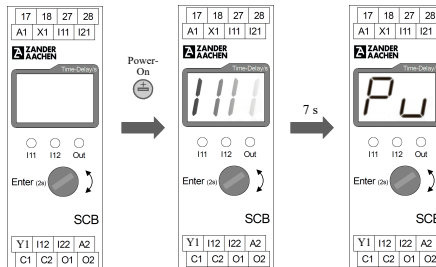

Figure 18: Display during entry into menu item PUK

After the menu item "Pu" has been displayed for approx. 2 seconds, the PUK can be entered (see Figure 19).

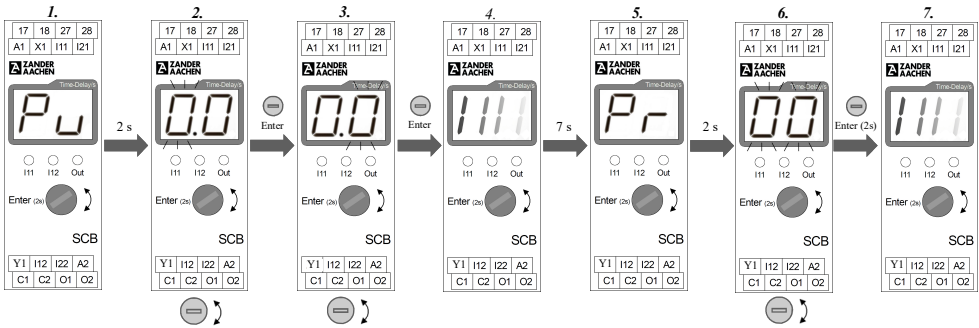

Figure 19: PUK procedure

1. bis 3. PUK entry:

first digit of the PUK is set by turning the push/rotary button. The first PUK digit is saved by pressing the button briefly and the second PUK digit can be set in the same way as the first one. The PUK Entry is ended by pressing the button briefly. To select the configuration of the SCB, enter the following PUK: **6 - 1**

In case of wrong PUK entry, an error indication „Er17“ appears. The error should be acknowledged by pressing the button for 2 s.

After acknowledgement, it will go back to step 1. The entry can be made again.

TIP: To abort the PUK entry, disconnect the supply voltage of the device. On reset the SCB starts with the previously parametrized delay time and configuration.

4. to 7. Select and load configuration

After successful PUK entry, the access to the configuration selection is signalled by the indication „Pr“. The desired configuration can now be loaded by turning the push/rotary button. After selection of the desired configuration, it is confirmed by pressing the button for 2 seconds. The SCB loads the new configuration and restarts.

INFO: A new configuration is always loaded with a preset delay time of 0.0 s/min/h.



ATTENTION!

- If the starting behaviour "automatic reset" is selected and the safety circuit closed, the SCB will be activated immediately

13.2 Parametrization of a delay time

ATTENTION: Make sure that during the loading of the new configuration the supply voltage of the the unit's power supply is securely connected. A power-off during the charging process will result in a non-acknowledgeable error condition.

After a configuration has been successfully loaded via the PUK, the desired delay time can be parameterised. The parametrization of the delay time is protected against external adjustment by PIN 4 - 2.

After successful entry, the delay time can be set via the push/rotary button and the display, depending on the time variant, in the range between 0.1 and 99 s/min/h with a resolution of ≥ 0.1 s/min/h as shown in Figure 20.

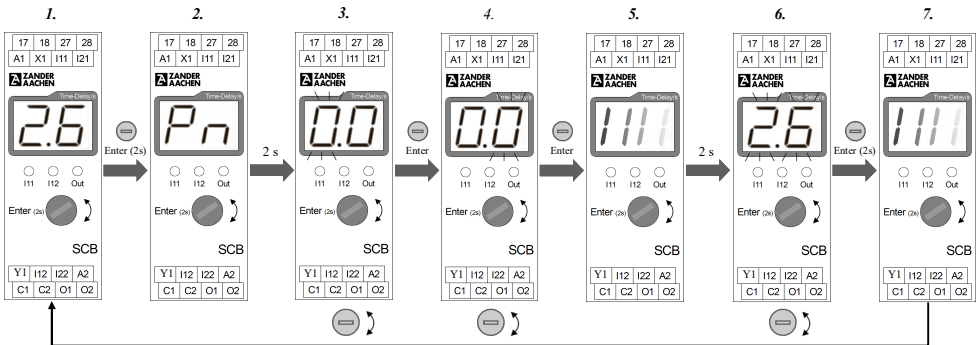

Figure 20: PIN procedure

1. Operating state

The parametrise menu is entered by pressing the push/rotary button for 2 s.

INFO: PIN request can be entered only in safe state. Open the safety circuit and wait until all safety outputs/contacts have switched off.

2. to 5. PIN entry

The access to PIN Entry is signalled by the indication „Pn“. The first digit of the PIN is shown as blinking. The first digit of the PIN is set by turning the push/rotary button. The first PIN digit is saved by pressing the button briefly and the second PIN digit can be set in the same way as the first one. The PIN entry is ended by pressing the button briefly.

INFO: The PIN of the SCB is: **4 - 2**

In case of wrong PIN entry, an error indication „Er18“ appears. The error should be acknowledged by pressing the button for 2 s.

ATTENTION: After acknowledgement, the SCB goes back into the operating mode. If the starting behaviour "automatic reset" is selected and the safety circuit closed, the SCB will be activated immediately

6. Parametrizing the delay time

After successful PIN entry, the delay time can be set by turning the push/rotary button. The delay time is confirmed and saved by pressing the button for 2 s.

TIP: To abort the parametrising, disconnect the supply voltage of the device.

7. System restart

The SCB applies the delay time.



ATTENTION!

- If the starting behaviour "automatic reset" is selected and the safety circuit closed, the SCB will be activated immediately

14. Commissioning procedure

1. Wiring the supply voltage

Connect the supply voltage to the device according to chapter 12.4.

2. Set desired device configuration and delay time

Supply the device with power and set the desired device configuration and delay time (see chapter 13). After successful parameterization of the device, disconnect the supply voltage for the remaining wiring.

3. Wiring reset circuit

Wire the reset circuit as described in chapter 12.1, taking into account the selected reset configuration.

Attention: If the starting behaviour "automatic reset" is selected and the safety circuit closed, the SCB will be activated immediately

4. Wiring feedback circuit

If your application requires external contactors or expansion modules, connect them to the device for monitoring in accordance with Chapter 12.2.

5. Wiring safety circuit

Wire the safety circuit according to your application according to chapter 12.3.

6. Wiring safe relay contacts and safe semiconductor outputs

Wire the safe outputs and/or safe contacts according to chapter 12.5.

7. Wiring auxiliary outputs

Wire the auxiliary outputs according to chapter 12.6.

8. Start the device

Switch on the supply voltage and wait until the device has reached the operating mode (the currently configured delay time is shown on the display).

Close the safety circuit and execute a proper reset command depending on the selected configuration.

The safe outputs/contacts as well as the status LEDs are activated taking into account the set configuration and delay time.

9. Trigger safety function

Open the safety circuit. The safe outputs/contacts as well as the status LEDs are deactivated according to the set configuration and delay time.

15. Diagnostic functions

The SCB has several diagnostic options. In addition to a two-digit display, which shows the currently parameterized delay time and configuration as well as error messages, three status LEDs are available for the IO status display.

Table 3 explains the symbols of the status LEDs used in the following.

Status LED	Description of the status
	I11/I12: Low at input. Out: Safety outputs not switched.
	I11/I12: High at input. Out: Safety outputs not switched.
	Out: Time-delay of outputs is running.

Table 2 - Symbol explanations Status-LED's

15.1 Operating state with Off-delay outputs/contacts

In the operating state, the current status of the SCB is shown on the display and the LEDs.

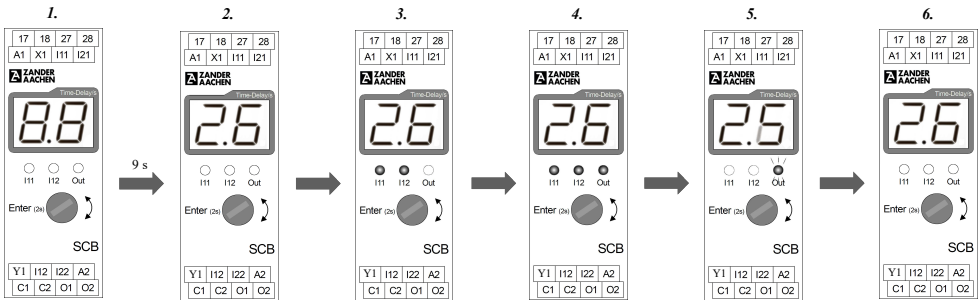

Figure 21: Display operating mode

1. Power-On

After the supply voltage is applied, the SCB carries out a self-test (duration approx. 9 seconds). At the same time, each individual segment is controlled on the display, whereby the display can be checked for possible errors.

TIP: Checking the display before re-parametrising avoids possible incorrect settings due to display errors.

2. to 4. Operating state

In the operating state, the display shows the delay time currently stored in the SCB. The three LEDs I11, I12 and Out provide information about the current status of the inputs and outputs.

INFO:

Picture 2: Current delay time is 2.6 s. Inputs and outputs are not activated

Picture 3: Inputs I11/I12 are activated, outputs are not activated

Picture 4: Inputs I11/I12 and outputs are activated

5. Requesting the safety function

Through the opening of the safety circuit, the non-delayed outputs/contacts are immediately switched off and the parametrized delay time is started. The blinking Out LED as well as the countdown shown on the display provide information on the running delay time.

INFO: The countdown is used only for monitoring. Deviations from the actual delay time can occur especially in long delay times. This function is available for all variants with a time range from 0.0 to 99 seconds.

6. Safe state

At the end of the delay time, the delayed outputs/contacts switch off and the currently saved delay time is again shown on the display.

15.2 Operating state with On-delay outputs/contacts

1. Power-On

After the supply voltage is applied, the SCB carries out a self-test (duration approx. 9 seconds). At the same time, each individual segment is controlled on the display, whereby the display can be checked for possible errors.

TIP: Checking the display before re-parametrising avoids possible incorrect settings due to display errors.

2. Operating state

In the operating state, the display shows the delay time currently stored in the SCB. The three LEDs I11, I12 and Out provide information about the current status of the inputs and outputs.

3. to 4. Closing of the safety circuit

Through the closing of the safety circuit in combination with a start, the non-delayed outputs/contacts are immediately switched on. The blinking Out LED as well as the countdown shown on the display provide information on the running delay time of the delayed outputs (depends on the variant).

INFO: The countdown is used only for monitoring. Deviations from the actual delay time can occur especially in long delay times. This function is available for all variants with a time range from 0.0 to 99 seconds.

5. Outputs switched

At the end of the delay time, the delayed outputs/contacts switch on and the delay time currently saved is again shown on the display.

6. Safe state

Through the opening of the safety circuit the outputs/contacts switch off immediately and the delay time currently saved is shown on the display.

15.3 Configuration display

The information on the configuration currently loaded in the SCB can be read on the display by pressing the push/rotary button briefly. „Pr“ and the current configuration number are displayed in an alternating manner for 2 seconds.

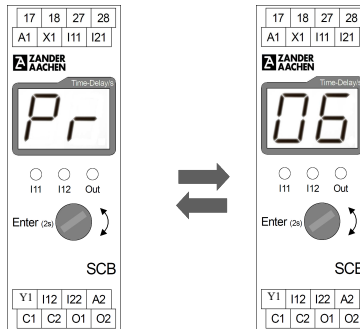

Figure 22: Configuration

15.4 Error monitoring

Detected errors are displayed on the SCB as shown in Figure 23.

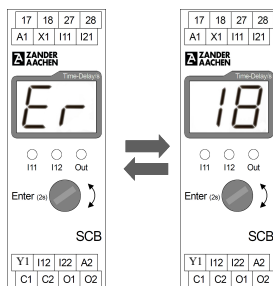

Figure 23: Error number on display

Table 3 lists all error numbers with corresponding possible solutions.

NOTE:

Error numbers are valid for units from unit version Ver. B (see information on the type plate). For SCB of an older unit version, please refer to the respective operating manual enclosed with the unit.

Nr.	Ursache	Lösung / Quittierung
Er01	Input pair I11-I21 / I12-I22: Difference time is exceeded or single channel is switched off and switched-on again	<ul style="list-style-type: none"> • Check wiring • Check the function of the connected sensor • Acknowledgement by opening and closing the safety circuit within the difference time (3 s)
Er11	Hung reset button. Input X1 (if manual, monitored resetis configured)	<ul style="list-style-type: none"> • Choose configuration with manual reset, but wired as autom.reset • Check wiring • Check the function of the start button • Acknowledgement by switching off and again switching on the reset button
Er17	PUK Incorrect	<ul style="list-style-type: none"> • Acknowledgement by pressing the button for 2 seconds
Er18	PIN Incorrect	<ul style="list-style-type: none"> • Acknowledgement by pressing the button for 2 seconds
Er49	Waiting state for the transition into an error mode (e.g. on expiry of a configured delay time)	<ul style="list-style-type: none"> • Wait for the original fault number
Er21	Fault on Input circuit channel 1	<ul style="list-style-type: none"> • Check wiring for cross circuits and short circuits • Check assignment: I21 → I11; I22 → I12 • Acknowledgement by pressing the button
Er22	Fault on Input circuit channel 2	<ul style="list-style-type: none"> • Check wiring for cross circuits and short circuits • Check assignment: I21 → I11; I22 → I12 • Acknowledgement by pressing the button
Er38 to Er43	Variant SCB-02: Internal error Variant SCB-03: Er38/Er41: Error at output O1 Er39/Er42: Error at output O2 Er40/Er43: Error at output O3 Variant SCB-04: Er38/Er41: Error at output O1 Er39/Er42: Error at output O2 Er40/Er43: Internal error	<ul style="list-style-type: none"> • Restart the device <i>If the problem persists:</i> • Check load at O1/O2/O3 <ul style="list-style-type: none"> - Short-Circuit occurred? - Capacity load to high (refer to Techn. Data) If so, correct error and restart device <i>If the problem persists:</i> • Reset the device via PUK to „Pr00“ <i>If the problem persists:</i> • Contact the support of the manufacturer

Nr.	Ursache	Lösung / Quittierung
Er44 to Er46	Inteferences at the supply voltage or outputs. Depending on the variant O1, O2, O3	<ul style="list-style-type: none"> Restart the device <i>If the problem persists:</i> <ul style="list-style-type: none"> Check power supply and output lines for possible sources of interference. Use adequate protective circuits for switching elements which generates inteferences. <i>If the problem persists:</i> <ul style="list-style-type: none"> Contact the support of the manufacturer
Er60 to Er65	Variant SCB-02: Internal error Variant SCB-03: Er60 / Er63: Error at output O1 Er61 / Er64: Error at output O2 Er62 / Er65: Error at output O3 Variant SCB-04: Er60 / Er63: Error at output O1 Er61 / Er64: Error at output O2 Er62 / Er65: Internal error	<ul style="list-style-type: none"> Restart the device <i>If the problem persists:</i> <ul style="list-style-type: none"> Check connected load at O1/O2/O3 - Shor circuit occured? If so, correct error and restart device <i>If the problem persists:</i> <ul style="list-style-type: none"> Reset the device via PUK to „Pr00“ <i>If the problem persists:</i> <ul style="list-style-type: none"> Contact the support of the manufacturer
Er51 to Er59 Er66 to Er99	Operation outside the technical data internal error	<ul style="list-style-type: none"> Check actual switching frequency at Inputs. Adjust if necessary. Max. 0.8 Hz (refer to technical data) Check for contact bouncing of used sensor an input circuit <ul style="list-style-type: none"> Restart the device <i>If the problem persists:</i> <ul style="list-style-type: none"> Reset the device via PUK to „Pr00“ <i>If the problem persists:</i> <ul style="list-style-type: none"> Contact the support of the manufacturer

Table 3: Error number list

15.5 Error memory

From unit version Ver. B onwards (see information on the type plate), the SCB has an error memory which can be queried via the menu. The last 10 errors displayed by the unit are stored here.

The error numbers are stored in memory locations "0" to "9". The last recent entry is in memory location "0" and the oldest entry is in memory location "9".

If the error memory is full with 10 entries, the error number stored at position "9" is deleted with the next error display. The entries of the other positions are shifted up one position and the new error number is entered at position "0".

The error memory is called up by pressing a button twice on the front of the unit. After a short running light, the first digit, is displayed.

The memory location "1" and the respective error number (e.g. "01") are displayed alternately. Turn the push/rotary button to navigate between the memory locations. If a memory location is not occupied, this is indicated by "- -".

The error memory display is exited by pressing the button twice again. After a short running light, the delay time currently parameterised in the unit is displayed again.

16. Configuration tables

! **ATTENTION:** If no point is set in a cell for an output, wiring of the respective output is not permitted.

16.1 Configuration table for variants SCB-04, SCB-04m, SCB-04h

Configuration No.			Non-delayed outputs/contacts				Delayed outputs/contacts				AUX Function		Function
Auto reset	Man. reset	Man. reset with autom. re-triggering	O1	O2	17/18	27/28	O1	O2	17/18	27/28	C1	C2	
00	11		•	•	•	•					F1	F2	None
01	12			•	•	•	•				F1	F2	On-Delay
02	13				•	•	•	•			F1	F2	
03	14		•	•					•	•	F1	F2	
04	15		•					•	•	•	F1	F2	
05	16							•	•	•	F1	F2	Off-Delay
06	17	22		•	•	•	•				F1	F2	
07	18	23			•	•	•	•			F1	F2	
08	19	24	•	•					•	•	F1	F2	
09	20	25	•					•	•	•	F1	F2	Time delayed reset
10	21	26					•	•	•	•	F1	F2	
27 - For variant SCB-04							•		•	•	F5	F6	None
27 - For variant SCB-04m-01 / SCB-04h-01			•	•	•	•					F1	F2	Wiping
28			•						•	•	F1	F2	Wiping
	29		•						•	•	F1	F2	Wiping

Table 4: Configuration table - SCB-04, SCB-04m, SCB-04h

Legend : F1: AUX C1 serves as immediate output for the time-delayed safe outputs/contacts
 F2: AUX C2 serves as fault signaling
 F5: AUX C1 switches inverted to safe relay contacts 17-18/27-2
 F6: AUX C2 switches parallel to safe relay contacts 17-18/27-28

16.2 Configuration table for variants SCB-04-01, SCB-04m-01, SCB-04h-01

Configuration No.			Non-delayed outputs/contacts				Delayed outputs/contacts				AUX Function		Function
Auto reset	Man. reset	Man. reset with autom. re-triggering	O1	O2	17/18	27/28	O1	O2	17/18	27/28	C1	C2	
00	11		•	•	•	•					F3	n.F.	None
01	12			•	•	•	•				F3	F4	On-Delay
02	13				•	•	•	•			F3	F4	
03	14		•	•					•	•	F3	F4	
04	15		•					•	•	•	F3	F4	
05	16							•	•	•	n.F.	F4	Off-Delay
06	17	22		•	•	•	•				F3	F4	
07	18	23			•	•	•	•			F3	F4	
08	19	24	•	•					•	•	F3	F4	
09	20	25	•					•	•	•	F3	F4	Time delayed reset
10	21	26					•	•	•	•	n.F.	F4	
27 - For variant SCB-04-01							•		•	•	F5	F6	None
27 - For variant SCB-04m-01 / SCB-04h-01			•	•	•	•					F3	n.F.	Wiping
28			•						•	•	F5	F6	Wiping
	29		•						•	•	F5	F6	Wiping

Table 5: Configuration table - SCB-04-01, SCB-04m-01, SCB-04h-01

Legend : F3: AUX C1 switches inverted to non-time-delayed safe outputs/contacts
 F4: AUX C2 switches inverted to time-delayed safe outputs/contacts
 F5: AUX C1 switches inverted to safe relay contacts 17-18/27-28
 F6: AUX C2 switches parallel to safe relay contacts 17-18/27-28
 n.F.:Corresponding AUX has no function

16.3 Configuration table for variants SCB-03, SCB-03m, SCB-03h

Configuration No.			Non-delayed outputs			Delayed outputs			AUX funktion		Function
Auto reset	Man. reset	Man. reset with autom. re-triggering	O1	O2	O3	O1	O2	O3	C1	C2	
00	07		●	●	●				F1	F2	None
01	08			●	●	●			F1	F2	On-Delay
02	09				●	●	●		F1	F2	
03	10					●	●	●	F1	F2	
04	11	14		●	●	●			F1	F2	Off-Delay
05	12	15			●	●	●		F1	F2	
06	13	16				●	●	●	F1	F2	
17			●					●	F1	F2	Wiping
	18		●					●	F1	F2	Wiping

Table 6: Configuration table - SCB-03, SCB-03m, SCB-03h

Legend : F1: AUX C1 serves as immediate output for the time-delayed safe outputs/contacts
 F2: AUX C2 serves as fault signaling

16.4 Configuration table for variants SCB-03-01, SCB-03m-01, SCB-03h-01

Configuration No.			Non-delayed outputs			Delayed outputs			AUX funktion		Function
Auto reset	Man. reset	Man. reset with autom. re-triggering	O1	O2	O3	O1	O2	O3	C1	C2	
00	07		●	●	●				F3	n.F.	None
01	08			●	●	●			F3	F4	On-Delay
02	09				●	●	●		F3	F4	
03	10					●	●	●	n.F.	F4	
04	11	14		●	●	●			F3	F4	Off-Delay
05	12	15			●	●	●		F3	F4	
06	13	16				●	●	●	n.F.	F4	
17			●					●	F5	F6	Wiping
	18		●					●	F5	F6	Wiping

Table 7: Configuration table - SCB-03-01, SCB-03m-01, SCB-03h-01

Legend : F3: AUX C1 switches inverted to non-time-delayed safe outputs/contacts
 F4: AUX C2 switches inverted to time-delayed safe outputs/contacts
 F5: AUX C1 switches inverted to O3
 F6: AUX C2 switches parallel to O3
 n.F.:Corresponding AUX has no function

16.5 Configuration table for variants SCB-02, SCB-02m, SCB-02h

Configuration No.			Non-delayed contacts		Delayed contacts		AUX function		Function
Auto reset	Man. reset	Man. reset with autom. re-triggering	17/18	27/28	17/18	27/28	C1	C2	
00	03		●	●			F1	F2	None
01	04				●	●	F1	F2	On-Delay
02	05	06			●	●	F1	F2	Off-Delay

Table 8: Configuration table - SCB-02, SCB-02m, SCB-02h

Legend : F1: AUX C1 serves as immediate output for the time-delayed safe outputs/contacts

F2: AUX C2 serves as fault signaling

16.6 Configuration table for variants SCB-02-01, SCB-02m-01, SCB-02h-01

Configuration No.			Non-de'layed contacts		Delayed contacts		AUX function		Function
Auto reset	Man. reset	Man. reset with autom. re-triggering	17/18	27/28	17/18	27/28	C1	C2	
00	03		●	●			F5	F6	None
01	04				●	●	F5	F6	On-delay
02	05	06			●	●	F5	F6	Off-delay

Table 9: Configuration table - SCB-02-01, SCB-02m-01, SCB-02h-01

Legend : F5: AUX C1 switches parallel to safe contacts

F6: AUX C2 switches inverted to safe contacts

17 Timing diagrams

17.1 Timing diagram SCB-04 with configuration Pr04

Table 10 shows the corresponding extract from the configuration table.

Configuration No.			Non-delayed outputs/contacts				Delayed outputs/contacts				AUX Function		Function
Auto reset	Man. reset	Man. reset with autom. re-triggering	O1	O2	17/18	27/28	O1	O2	17/18	27/28	C1	C2	
04			●					●	●	●	F1	F2	On-delay

Table 10: Extract from Configuration table SCB-04 - Configuration Pr04

Legend : F1: AUX C1 serves as immediate output for the time-delayed safe outputs/contacts
 F2: AUX C2 serves as fault signaling

Figure 24 shows the timing diagram for Configuration Pr04.

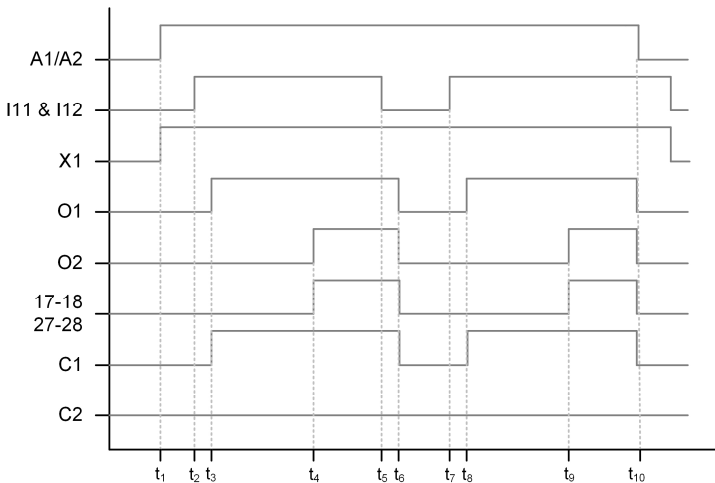

Figure 24: Timing diagram for SCB-04 with Configuration Pr04 (Qualitative representation)

- t₁: Power supply activation
- t₂: Safety circuit I11/I12 is closed
- t₃: Output O1 and C1 are switches on immediately (reaction time)
- t₄: After the parametric delay time has elapsed, output O2 and the relay contacts 17-18/27-28 switches on
- t₅: Requirement of the safety function by opening the safety circuit at I11/I12
- t₆: Outputs O1 and O2, relay contacts 17-18 / 27-28 and C1 switches off without any delay time
- t₇: Safety circuit I11/I12 is closed
- t₈: Output O1 and C1 are switches on immediately (reaction time)
- t₉: After the parametrized delay time has elapsed, output O2 and the relay contacts 17-18/27-28 switches on
- t₁₀: Power supply is switched off. All outputs and relay contacts switch off immediately

17.2 Timing diagram SCB-04 with Configuration Pr19

Table 11 shows the corresponding extract from the configuration table.

Configuration No.			Non-delayed outputs/contacts				Delayed outputs/contacts				AUX Function		Function
Auto reset	Man. reset	Man. reset with autom. re-triggering	O1	O2	17/18	27/28	O1	O2	17/18	27/28	C1	C2	
	19		●	●					●	●	F1	F2	Off-delay

Table 11: Extract from Configuration table SCB-04 - Configuration Pr19

Legend : F1: AUX C1 serves as immediate output for the time-delayed safe outputs/contacts
 F2: AUX C2 serves as fault signaling

Figure 25 shows the timing diagram for Configuration Pr19.

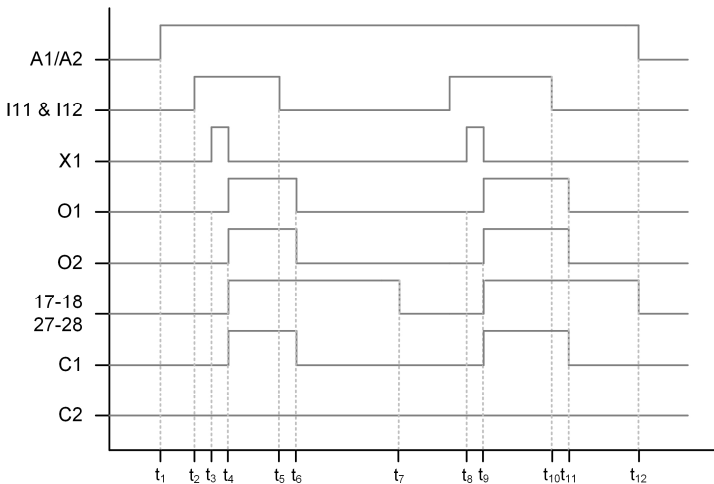

Figure 25: Timing diagram for SCB-04 with Configuration Pr19 (Qualitative representation)

- t₁: Power supply activation
- t₂: Safety circuit I11/I12 is closed. Outputs/contacts are not yet switched
- t₃: Pressing the reset button at X1
- t₄: All outputs/contacts are activated with the falling edge of the reset button
- t₅: Requirement of the safety function by opening the safety circuit I11/I12
- t₆: Outputs O1, O2 and C1 are switches off immediately (reaction time)
- t₇: Relay contacts 17-18/27-28 switches off after the parameterized delay time has elapsed
- t₈: Safety circuit I11/I12 is closed. Outputs/contacts are not yet switched
- t₉: All outputs/contacts are activated with the falling edge of the reset button
- t₁₀: Requirement of the safety function by opening the safety circuit I11/I12
- t₁₁: Outputs O1, O2 and C1 are switched off immediately, taking the reaction times into account
- t₁₂: Power supply switch off. All outputs and relay contacts switch off immediately

17.3 Timing diagram SCB-04-01 with Configuration Pr24

Table 12 shows the corresponding extract from the configuration table.

Configuration No.			Non-delayed outputs/contacts				Delayed outputs/contacts				AUX Function		Function
Auto reset	Man. reset	Man. reset with autom. re-triggering	O1	O2	17/18	27/28	O1	O2	17/18	27/28	C1	C2	
		24	●	●					●	●	F3	F4	Off-delay

Table 12: Extract from Configuration table SCB-04-01 - Configuration Pr24

Legend : F3: AUX C1 inverted signal for non-time-delayed safe outputs/contacts
 F4: AUX C2 inverted signal for time-delayed safe outputs/contacts

Figure 26 shows the timing diagram for Configuration Pr24.

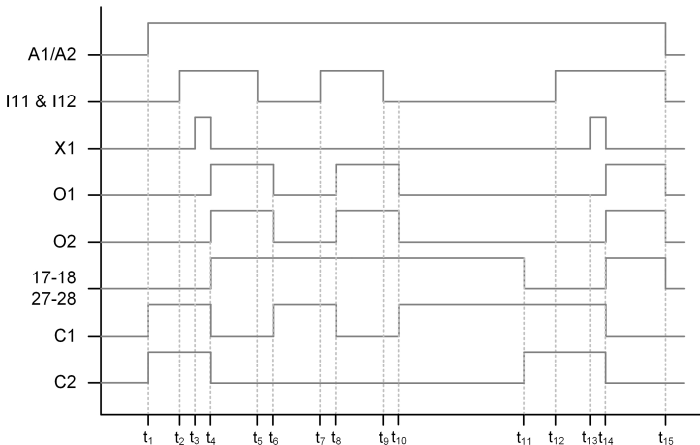

Figure 26: Timing diagram for SCB-04-01 with Configuration Pr24 (Qualitative representation)

- t₁: Activation of the power supply. The C1 and C2 are activated as soon as the device is ready for operation
- t₂: Safety circuit I11/I12 is closed. Outputs/contacts are not yet switched
- t₃: Pressing the reset button at X1
- t₄: All safe outputs/contacts are activated with the falling edge of the reset button and the AUX switches off
- t₅: Requirement of the safety function by opening the safety circuit I11/I12
- t₆: Outputs O1, O2 switches off immediately (reaction time). C1 switch on
- t₇: Safety circuit I11/I12 is closed again before the delay time has elapsed
- t₈: Without pressing the reset button at X1, O1 and O2 are reactivated and C1 switch off. The current delay time for 17-8 / 27-28 is stopped and reset. Relay contacts 17-18/27-28 stays activated
- t₉: Request for safety function by opening safety circuit I11/I12
- t₁₀: Outputs O1, O2 switches off immediately (reaction time). C1 switch on
- t₁₁: After the parameterized delay time has elapsed, the relay contacts 17-18/27-28 switch off and C2 switch on
- t₁₂: Safety circuit I11/I12 is closed. Outputs/contacts are not yet switched
- t₁₃: Pressing the reset button at X1
- t₁₄: With the falling edge of the reset button, O1, O2 and 17-18/27-28 switch on and C1 and C2 switch off
- t₁₅: Power supply is switched off. All outputs and relay contacts switch off immediately

17.4 Timing diagram SCB-04 with Configuration Pr28

Table 13 shows the corresponding extract from the configuration table.

Configuration No.			Non-delayed outputs/contacts				Delayed outputs/contacts				AUX Function		Function
Auto reset	Man. reset	Man. reset with autom. re-triggering	O1	O2	17/18	27/28	O1	O2	17/18	27/28	C1	C2	
28			●						●	●	F1	F2	Wischer

Table 13: Extract from Configuration table SCB-04-01 - Configuration Pr28

Legend : F1: AUX C1 serves as immediate output for the time-delayed safe outputs/contacts
 F2: AUX C2 serves as fault signaling

Figure 27 shows the timing diagram for Configuration Pr28.

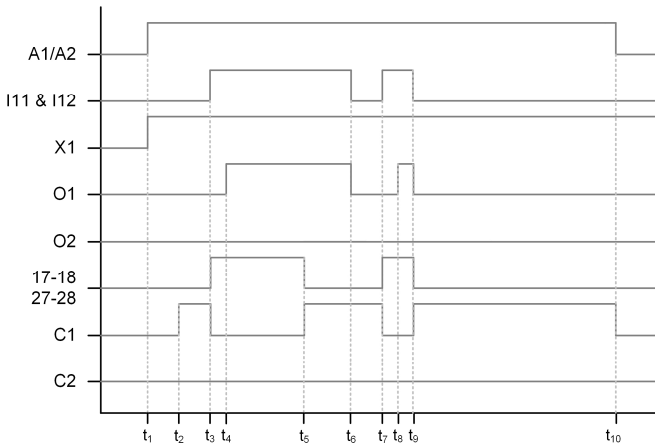

Figure 27: Timing diagram for SCB-04 with Configuration Pr28 (Qualitative representation)

- t₁: Activation of the power supply and Input X1
- t₂: C1 is activated as soon as the unit is ready for operation
- t₃: Safety circuit I11/I12 is closed. Relay contacts 17-18 and 27-28 are switched taking into account the reaction times and C1 is deactivated.
- t₄: Switching the relay contacts 17-18 and 27-28 activates O1
- t₅: After the set delay time has elapsed, the relay contacts 17-18 and 27-28 are switched off again and C1 is activated.
- t₆: Opening of the safety circuit I11/I12. O1 remains activated until this time.
- t₇: Safety circuit I11/I12 is closed. Relay contacts 17-18 and 27-28 are switched taking into account the reaction times and C1 is deactivated.
- t₈: Switching the relay contacts 17-18 and 27-28 activates O1
- t₉: Opening of the safety circuit before the set delay time has elapsed. Relay contacts 17-18 and 27-28 and output O1 are switched off immediately. Message output C1 is activated.
- t₁₀: The power supply is switched off. All outputs and relay contacts switch off immediately

17.4 Timing diagram SCB-04-01 with Configuration Pr27

Table 14 shows the corresponding extract from the configuration table.

Configuration No.			Non-delayed outputs/contacts				Delayed outputs/contacts				AUX Function		Function
Auto reset	Man. reset	Man. reset with autom. re-triggering	O1	O2	17/18	27/28	O1	O2	17/18	27/28	C1	C2	
27							•		•	•	F5	F6	Time delayed reset

Table 14: Extract from Configuration table SCB-04-01 - Configuration Pr27

Legende: F5: AUX C1 switches inverted to safe relay contacts 17-18/27-28
 F6: AUX C2 switches parallel to safe relay contacts 17-18/27-28

Figure 28 shows the timing diagram for Configuration Pr27.

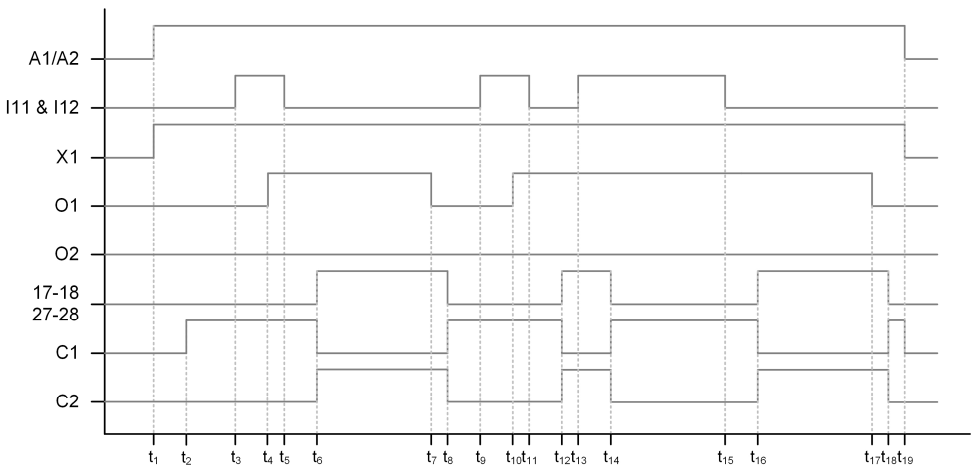

Figure 28: Timing diagram for SCB-04-01 with Configuration Pr27 (Qualitative representation)

- t₁: Power-On. SCB performs selftest (approx. 9 seconds).
- t₂: Selftest ok. Actual parameterized delay time is shown on display (e.g. 5.0). Auxiliary outputs switches according configuration.
- t₃: Activating safety inputs I11 and I12.
- t₄: Safe semiconductor output O1 switches on.
- t₅: Deactivation safety inputs I11 and I12.
- t₆: Safe relay contacts 17-18 und 27-28 switches on. Auxiliary outputs switches according configuration.
- t₇: Safe semiconductor output O1 switches off.
- t₈: Safe relay contacts 17-18 und 27-28 switches off after parameterized delay time has elapsed. Auxiliary outputs switches according configuration.
- t₉: Re-activation of the safety inputs.
- t₁₀: Safe semiconductor output O1 switches on.
- t₁₁: Deactivation safety inputs I11 and I12.
- t₁₂: Safe relay contacts 17-18 und 27-28 switches on. Auxiliary outputs switches according configuration.
- t₁₃: Re-activation of the safety inputs.
- t₁₄: Safe relay contacts 17-18 und 27-28 switches off. Auxiliary outputs switches according configuration.
- t₁₅: Deactivation safety inputs I11 and I12.
- t₁₆: Safe relay contacts 17-18 und 27-28 switches on. Auxiliary outputs switches according configuration.
- t₁₇: Safe semiconductor output O1 switches off.
- t₁₈: Safe relay contacts 17-18 und 27-28 switches off after parameterized delay time has elapsed. Auxiliary outputs switches according configuration.
- t₁₉: Power-Off. The entire device is deactivated when the power supply is switched off (Current delay times are not taken into account).

18. Dimensions

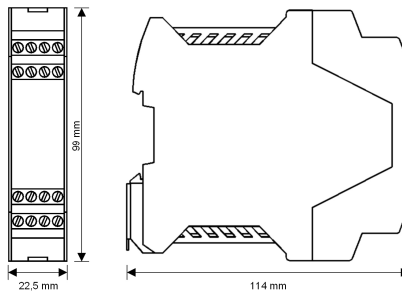

Figure 29: Dimensions of the SCB

19. Safety parameters

Calculation of characteristic values for the relay contacts under the following assumptions:			
DC-13; DC 24 V			
Load per contact	-	≤ 1 A	≤ 2 A
T _M [Year]	-	20	20
n _{op} [Max. cycles per year]	-	≤ 100,000	≤ 10,000
AC-15; AC 250 V			
Load per contact	≤ 0.5 A	≤ 1 A	≤ 2 A
T _M [Year]	20	20	20
n _{op} [Max. cycles per year]	≤ 65,000	≤ 20,000	≤ 5,000

Safety parameters according to EN ISO 13849-1, IEC 62061 und IEC 61508							
ATTENTION! According to CNB/M/11.050, a request for the safety function is recommended at the following intervals:							
<ul style="list-style-type: none"> Once a month for applications up to PL e with Cat. 3 respectively Cat. 4 or SIL 3 with HFT = 1 Once a year for applications up to PL d with Cat. 3 or SIL 2 with HFT = 1 							
Application	Output Contact	EN ISO 13849-1			IEC 62061 / IEC 61508		
		PL	Category	PFH _d [1/h]	SIL	PFD _{AVG}	PFH [1/h]
Single channel E-Stop (Fig. 10)	Semiconductor	c	1	1.14E-06	1	1.22E-04	1.39E-09
	Relay	c	1	1.14E-06	1	7.78E-04	8.88E-09
Dual channel E-Stop without cross-circuit monitoring (Fig. 9)	Semiconductor	d	3	1.03E-07	2	2.26E-05	2.58E-10
	Relay	d	3	1.03E-07	2	3.65E-05	4.21E-10
Dual channel E-Stop with cross-circuit monitoring (Fig. 8, 11, 12)	Semiconductor	e	4	7.04E-09	3	2.23E-05	2.55E-10
	Relay	e	4	2.47E-08	3	3.62E-05	4.18E-10

Safety parameters for use in furnaces in continuous mode according to EN 50156-1 und EN 746-2							
Application	Output Contact	IEC 62061 / IEC 61508					
		SIL	PFD _{avg}	PFH [1/h]	T _M [Jahr]	PTI [Jahr]	
Single channel E-Stop (Fig. 10)	Semiconductor	1	1.22E-04	1.39E-09	20	20	
	Relay	1	1.65E-04	1.89E-09	20	20	
Dual channel E-Stop without cross-circuit monitoring (Fig. 9)	Semiconductor	2	2.26E-05	2.58E-10	20	20	
	Relay	2	2.35E-05	2.68E-10	20	20	
Dual channel E-Stop with cross-circuit monitoring (Fig. 8, 11, 12)	Semiconductor	3	2.23E-05	2.55E-10	20	20	
	Relay	3	2.32E-05	2.65E-10	20	20	

Safety characteristics for alternate 1oo1 structure for process industry - High Demand

Conditions: Day of operation/year: 365; Hours/Day: 24; Switching-Cycle/Hour: 0,5; Maximum load AC-15/DC-13

	Relay	Semiconductor output
Device type	B	B
HFT	0	0
SIL	3	3
SFF [%]	99,92	99,92
λ_{SD} [FIT]	0,00	0
λ_{SU} [FIT]	458,57	292,96
λ_{OD} [FIT]	40,96	25,18
λ_{DU} [FIT]	0,41	0,25
PFH_D	4,10E-10	2,52E-10

Safety characteristics for alternate 1oo1 structure for process industry - Low Demand

	Relay	Semiconductor output
Gerätetyp	B	B
HFT	0	0
SIL	2	3
SFF [%]	98,01	99,91
λ_{SD} [FIT]	0,00	0,00
λ_{SU} [FIT]	292,08	290,43
λ_{OD} [FIT]	0	0,00
λ_{DU} [FIT]	5,92	0,25
PFD_{avg} (z.B. für T = 1 Jahr)	2,59E-05	1,11E-06

20. Technical data

Electrical data	
Operating voltage	U _B : DC 24 V
Voltage tolerance	+ 10 % / - 15 %
Power consumption (no load) at U _B	3.6 W
Display	2-digit x 7-segment LED display; 3 LEDs
Power-on delay	9 s
Two-channel safety inputs	
Number	1
Input current at high level	Type 7 mA
Galvanic isolation	no
Low level	min: 0 V; max: 5 V
High level	min: 18 V; max: U _B
Max. Switch on delay	800 ms (+ configured delay times, if applicable)
Max. switching frequency	0,8 Hz
Max. Time between I1 and I2	3 seconds
Max. cable length input circuit	700 m
Start input/ feedback circuit	
Number	per 1
Function	X1:Auto start / monitored manual start (depending on configuration) Y1: Monitoring of external contactors or expansion modules
Input current at high level	Typ. 7 mA
Galvanic isolation	no
Low level	min: 0 V; max: 5 V
High level	min: 18 V; max: U _B

Safety semiconductor outputs

Number	
SCB-02 (all variants)	0
SCB-03 (all variants)	3
SCB-04 (all variants)	2
Structure	PNP outputs, diverse
Switching capacity per output	$U_B / 500 \text{ mA}$
Max. capacity load	0.5 μF per 10 mA output current
Max. Pulse duration for selftest	< 3 ms
Galvanic isolation	no
Short-circuit-proof	yes
Max. switch-off delay	160 ms (+ configured delay times, if applicable)
Output voltage at "1" (max. load)	$U_B - 1 \text{ V}$

Safety relay contacts

Number	
SCB-02 (all variants)	2
SCB-03 (all variants)	0
SCB-04 (all variants)	2
Switching capacity per contact (0,1 Hz)	AC: 250 V, 1000 VA, 4 A for resistive load DC: 50 V, 200 W, 4 A for resistive load AC-15: 2 A / AC 250 V; DC-13: 3 A / DC 24 V UL: C300 / R300
Minimum contact load	10 V / 10 mA
Max. switch-off delay	160 ms (+ configured delay times, if applicable)
Contact fuse	6 A gG; Factor 0.6 for applications acc. to EN 50156-1 (See Chapter 10.5.5.3.4)
Contact material	AgNi; AgSnO ₂
Contact service life	mech. 1×10^7 switching cycles

Auxiliary outputs:

Number	2
Structure	PNP outputs, single channel
Switching capacity per output	
SCB-02 (all variants)	C1: $U_B / 200 \text{ mA}$; C2: $U_B / 50 \text{ mA}$
SCB-03 (all variants)	C1: $U_B / 500 \text{ mA}$; C2: $U_B / 50 \text{ mA}$
SCB-04 (all variants)	C1: $U_B / 500 \text{ mA}$; C2: $U_B / 50 \text{ mA}$
Galvanic isolation	no
Short-circuit-proof	yes
Output voltage at „1“ (max. load)	$U_B - 1 \text{ V}$

Environmental data

Ambient temperature	0 °C to +55 °C - see derating characteristic curves
Storage temperature	-20 °C to 85 °C
Humidity rating	93 % RH at +40 °C, non-condensing
EMC	EN 61326-3-1
Air and creepage distance	As per EN 60664-1
Overvoltage category / Degree of soiling	III / 2 (DIN VDE 0110-1)
Rated insulation voltage	50 V (For SELV/PELV circuit) 250 V (Between relay circuit and SELV/PELV circuit)
Rated surge voltage strength	800 V - Basic insulation for SELV/PELV circuit 6 kV - Safe insulation, reinforced insulation between relay circuit and SELV/PELV circuit

Mechanical data	
Degree of protection	IP20
Assembly	Mounting rail as per EN 60715TH35
Max. cable length	1000 m at 0.75 mm ²
Cable cross-section	0.25 - 2.5 mm ²
Dimensions (W x H x D)	22.5 x 99 x 118 mm
Weight	SCB-02/04: approx.145 g; SCB-03: approx.110 g (without packing)
Housing material	Polyamide PA6.6
Type of connection	Plug-in screw or tensile spring terminals

21. Derating

Figure 30 shows the total current limiting curve for 10 mm distance to adjacent, heat generating devices.

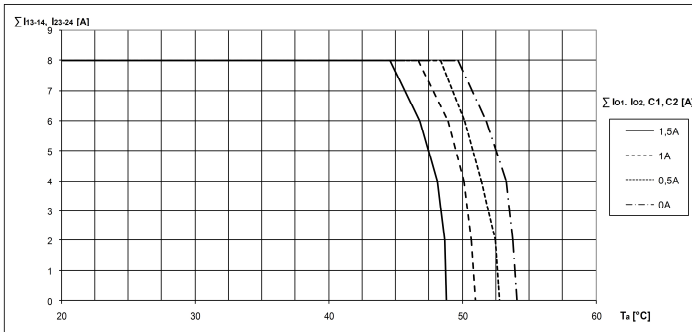

Figure 30: Total current limiting curve for 10 mm distance to adjacent, heat generating devices

Figure 31 shows the total current limiting curve for 10 mm distance to adjacent, non heat generating devices.

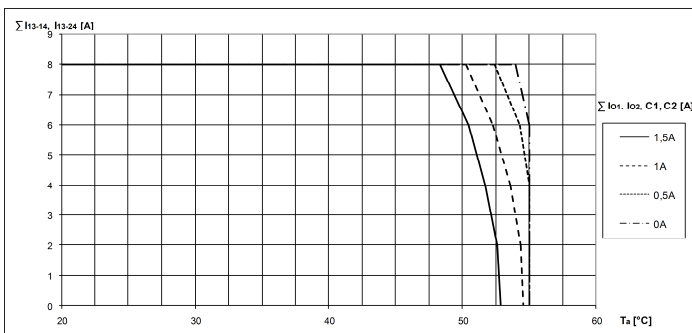

Figure 31: Total current limiting curve for 10 mm distance to adjacent, non heat generating devices

22. Variants

The SCB is available in different versions. These differ, for example, in the type and number of safe outputs/contacts, the function of the signal outputs or the terminal type.

To simplify the selection of your SCB, follow the following 4 steps and select the desired function. Table 13 will help you to find the right SCB for your requirements.

Step 1: Select the contact configuration. Choose between:

- 2 safe relay contacts
- 3 safe semiconductor outputs
- 2 safe relay contacts and 2 safe semiconductor outputs

Step 2: Select the time range:

- 0 to 99 seconds
- 0 to 99 minutes
- 0 to 99 hours

Step 3: Switching behaviour of the auxiliary outputs

- F1 and F2:
 - AUX C1 serves as immediate output for the time-delayed safe outputs/contacts
 - AUX C2 serves as fault signaling
- F3 and F4:
 - AUX C1 switches inverted to non-time-delayed safe outputs/contacts
 - AUX C2 switches inverted to time-delayed safe outputs/contacts
- F5 and F6:
 - AUX C1 switches parallel to safe contacts
 - AUX C2 switches inverted to safe contacts

Schritt 4: Type of terminals

- Plug-in screw terminals
- Plug-in spring-cage terminals

Step 1	Step 2	Step 3		Step 4	→	Your SCB	
Output/Contact configuration	Time range	Function AUX		Type of terminals	→	Type	Order No.:
		C1	C2				
2 safe relay contacts	0 to 99 sec.	F1	F2	screw	→	SCB-02	474490
				spring-cage	→	SCB-02	475490
		F5	F6	screw	→	SCB-02-01	474495
				spring-cage	→	SCB-02-01	475495
	0 to 99 min.	F1	F2	screw	→	SCB-02m	474491
				spring-cage	→	SCB-02m	475491
		F5	F6	screw	→	SCB-02m-01	474496
				spring-cage	→	SCB-02m-01	475496
	0 to 99 h.	F1	F2	screw	→	SCB-02h	474492
				spring-cage	→	SCB-02h	475492
		F5	F6	screw	→	SCB-02h-01	474497
				spring-cage	→	SCB-02h-01	475497
3 safe semiconductor outputs	0 to 99 sec.	F1	F2	screw	→	SCB-03	474480
				spring-cage	→	SCB-03	475480
		F3	F4	screw	→	SCB-03-01	474485
				spring-cage	→	SCB-03-01	475485
	0 to 99 min.	F1	F2	screw	→	SCB-03m	474481
				spring-cage	→	SCB-03m	475481
		F3	F4	screw	→	SCB-03m-01	474486
				spring-cage	→	SCB-03m-01	475486
	0 to 99 h.	F1	F2	screw	→	SCB-03h	474482
				spring-cage	→	SCB-03h	475482
		F3	F4	screw	→	SCB-03h-01	474487
				spring-cage	→	SCB-03h-01	475487
2 safe relay contacts and 2 safe semiconductor outputs	0 to 99 sec.	F1	F2	screw	→	SCB-04	474460
				spring-cage	→	SCB-04	475460
		F3	F4	screw	→	SCB-04-01	474465
				spring-cage	→	SCB-04-01	475465
	0 to 99 min.	F1	F2	screw	→	SCB-04m	474461
				spring-cage	→	SCB-04m	475461
		F3	F4	screw	→	SCB-04m-01	474466
				spring-cage	→	SCB-04m-01	475466
	0 to 99 h.	F1	F2	screw	→	SCB-04h	474462
				spring-cage	→	SCB-04h	475462
		F3	F4	screw	→	SCB-04h-01	474467
				spring-cage	→	SCB-04h-01	475467

Table 15: Selection list - SCB variants

Table 16 shows the list of variants, broken down by order number.

Variants incl. plug-in screw terminals:

Order no.	474460	SCB-04, DC 24 V,	2 semiconductor outputs, 2 relay contacts,	time range 0 - 99 s
Order no.	474480	SCB-03, DC 24 V,	3 semiconductor outputs, 0 relay contacts,	time range 0 - 99 s
Order no.	474490	SCB-02, DC 24 V,	0 semiconductor outputs, 2 relay contacts,	time range 0 - 99 s
Order no.	474461	SCB-04m, DC 24 V,	2 semiconductor outputs, 2 relay contacts,	time range 0 - 99 min
Order no.	474481	SCB-03m, DC 24 V,	3 semiconductor outputs, 0 relay contacts,	time range 0 - 99 min
Order no.	474491	SCB-02m, DC 24 V,	0 semiconductor outputs, 2 relay contacts,	time range 0 - 99 min
Order no.	474462	SCB-04h, DC 24 V,	2 semiconductor outputs 2 relay contacts,	time range 0 - 99 h
Order no.	474482	SCB-03h, DC 24 V,	3 semiconductor outputs, 2 relay contacts,	time range 0 - 99 h
Order no.	474492	SCB-02h, DC 24 V,	0 semiconductor outputs, 2 relay contacts,	time range 0 - 99 h
Order no.	474465	SCB-04-01, DC 24 V,	2 semiconductor outputs, 2 relay contacts,	time range 0 - 99 s
Order no.	474485	SCB-03-01, DC 24 V,	3 semiconductor outputs, 0 relay contacts,	time range 0 - 99 s
Order no.	474495	SCB-02-01, DC 24 V,	0 semiconductor outputs, 2 relay contacts,	time range 0 - 99 s
Order no.	474466	SCB-04m-01, DC 24 V,	2 semiconductor outputs 2 Relais-Kontakte,	time range 0 - 99 min
Order no.	474486	SCB-03m-01, DC 24 V,	3 semiconductor outputs, 0 relay contacts,	time range 0 - 99 min
Order no.	474496	SCB-02m-01, DC 24 V,	0 semiconductor outputs, 2 relay contacts,	time range 0 - 99 min
Order no.	474467	SCB-04h-01, DC 24 V,	2 semiconductor outputs, 2 relay contacts,	time range 0 - 99 h
Order no.	474487	SCB-03h-01, DC 24 V,	3 semiconductor outputs, 0 relay contacts,	time range 0 - 99 h
Order no.	474497	SCB-02h-01, DC 24 V,	0 semiconductor outputs, 2 relay contacts,	time range 0 - 99 h

Variants incl. plug-in spring-cage terminals:

Order no.	475460	SCB-04, DC 24 V,	2 semiconductor outputs, 2 relay contacts,	time range 0 - 99 s
Order no.	475480	SCB-03, DC 24 V,	3 semiconductor outputs, 0 relay contacts,	time range 0 - 99 s
Order no.	475490	SCB-02, DC 24 V,	0 semiconductor outputs, 2 relay contacts,	time range 0 - 99 s
Order no.	475461	SCB-04m, DC 24 V,	2 semiconductor outputs, 2 relay contacts,	time range 0 - 99 min
Order no.	475481	SCB-03m, DC 24 V,	3 semiconductor outputs, 0 relay contacts,	time range 0 - 99 min
Order no.	475491	SCB-02m, DC 24 V,	0 semiconductor outputs, 2 relay contacts,	time range 0 - 99 min
Order no.	475462	SCB-04h, DC 24 V,	2 semiconductor outputs 2 relay contacts,	time range 0 - 99 h
Order no.	475482	SCB-03h, DC 24 V,	3 semiconductor outputs, 0 relay contacts,	time range 0 - 99 h
Order no.	475492	SCB-02h, DC 24 V,	0 semiconductor outputs, 2 relay contacts,	time range 0 - 99 h
Order no.	475465	SCB-04-01, DC 24 V,	2 semiconductor outputs, 2 relay contacts,	time range 0 - 99 s
Order no.	475485	SCB-03-01, DC 24 V,	3 semiconductor outputs, 0 relay contacts,	time range 0 - 99 s
Order no.	475495	SCB-02-01, DC 24 V,	0 semiconductor outputs, 2 relay contacts,	time range 0 - 99 s
Order no.	475466	SCB-04m-01, DC 24 V,	2 semiconductor outputs 2 Relais-Kontakte,	time range 0 - 99 min
Order no.	475486	SCB-03m-01, DC 24 V,	3 semiconductor outputs, 0 relay contacts,	time range 0 - 99 min
Order no.	475496	SCB-02m-01, DC 24 V,	0 semiconductor outputs, 2 relay contacts,	time range 0 - 99 min
Order no.	475467	SCB-04h-01, DC 24 V,	2 semiconductor outputs, 2 relay contacts,	time range 0 - 99 h
Order no.	475487	SCB-03h-01, DC 24 V,	3 semiconductor outputs, 0 relay contacts,	time range 0 - 99 h
Order no.	475497	SCB-02h-01, DC 24 V,	0 semiconductor outputs, 2 relay contacts,	time range 0 - 99 h

Table 16: Variant list - SCB

23. Declaration of Conformity

Konformitätserklärung
EC Declaration of Conformity
Déclaration de conformité

Hersteller: H. ZANDER GmbH & Co. KG
Producer: Am Gut Wolf 15 • 52070 Aachen • Deutschland
Fabricant:

Produktgruppe: Sicherheits-Not-Halt-System
Product Group: Safety emergency stop system
Groupe de produits: Système de sécurité d'arrêt d'urgence

Produkt Name	Zertifikats-Nr.
Product Name	No of Certificate
Nom du produit	N° du certificat
TB-I14O3y	01/205/5420.02/21
TB-Modbus y	01/205/5420.02/21
SCB-0xyz.....	01/205/5420.02/21
Mit/with/avec: x = (2,3,4); y = (" ", m, h); z = (" ", -01)	

Die Produkte stimmen mit den Vorschriften folgender Europäischer Richtlinien überein:
 The products conform with the essential protection requirements of the following European directives.
 Les produits sont conformes aux dispositions des directives européennes suivantes:

2006/42/EG : Maschinenrichtlinie	2011/65/EU: RoHS Richtlinie
2006/42/EG : Machinery directive	2011/65/EU: RoHS directive
2006/42/EG : Directive Machines	2011/65/EU: Directive RoHS

2014/30/EU : EMV Richtlinie
2014/30/EU : EMC directive
2014/30/EU : Directive CEM

Die Übereinstimmung der bezeichneten Produkte mit den Vorschriften der o.a. Richtlinie wird, falls anwendbar, nachgewiesen durch die vollständige Einhaltung folgender Normen:
 If applicable, the conformity of the designated products is proved by full compliance with the following standards:
 Le strict respect des norms suivantes confirme, s'il y a lieu, que les produits désignés sont conformes aux dispositions de la directive susmentionnée:

EN 61326-3-1:2018-04	EN 55022
-----------------------------	-----------------

Gemäß Zertifikat der benannten Stelle:
 According to the certificate of the below mentioned organisation:
 Selon de organisme notifié:

EN 62061:2005 +AC:2010+A1:2013+A2:2015	EN ISO 13849-1:2015
IEC 61508 Parts 1-7:2010	IEC 61511-1:2016
EN 50156-1:2015 in extracts	EN 746-2:2010 in extracts

Benannte Stelle / Notified body / Organisme notifié: Nr. NB 0035 TÜV Rheinland Industrie Service GmbH 10882 Berlin Zertifizierungsstelle für Maschinen	Dokumentationsbeauftragte/-r: Christiane Nitschalk Documentation manager Autorisé à constituer le dossier technique
--	---

Aachen, den 23.08.2021 Dr.-Ing. Marco Zander Geschäftsleitung General Manager Direction	 Dipl.-Ing. Alfons Austerhoff Leiter CE-Konformitätsbewertung Manager for EC declaration of conformity Responsable évaluation de conformité CE
---	--

FT 3-07/03

