

General information

PVS520200513

The compression load cell 1000 is precise and robust and it has been designed to meet the requirements of a wide range of industrial weighing applications: hoppers, tanks, platforms. The load cell 1000 is able to work in severe environmental conditions typical of applications in food, chemical and pharmaceutical industries. Thanks to its small size, the load cell 1000 does not clutter and requires a very limited assembly space. Furthermore, it is possible to customize the compression load cell 1000. Our specialists guide customers towards the most suitable load cell.



Suggested related products

A highly performing weighing system must be accurate, perfectly calibrated and well maintained. In order to improve the load cell performance and to optimize its functioning, you may need the following products:

Weight Transmitter [UWT 6008](#)

Weight Transmitter [DAT 1400](#)

Tester 1008 [TESTER 1008](#)

Compression load cell [CC3](#)

Junction Box [CGS4-C](#)

Compression load cell [Tedeia 220](#)

All indicated data may be changed without notice.
All the measures indicated are expressed in millimeters (mm).

Technical specifications

PVS520200513

Rated load RL:	100, 250, 500, 1000 Kg
Combined error:	±0.1 % RO
Repeatability:	±0.02 % RO
Creep (20 minutes):	±0.03 % RO
Safe overload:	150 % RL
Ultimate overload:	> 300 % RL
Material:	Stainless steel
Degree of protection:	IP67
Deflection:	< 0.3 mm
Compensated Temperature:	-10 ÷ +50°C
Temperature range:	-20 ÷ +70°C
Temperature effect on zero balance:	±0.005 % RL/°C
Temperature effect on output:	±0.005 % load/°C
Rated output RO:	2 mV/V ±0.25 %
Zero balance:	±1 % RO
Insulation resistance:	> 5000 MOhm
Input resistance:	700 ± 20 Ohm
Output resistance:	705 ±5 Ohm
Recommended input:	5 ÷ 15 Vdc/Vac

All indicated data may be changed without notice.
All the measures indicated are expressed in millimeters (mm).

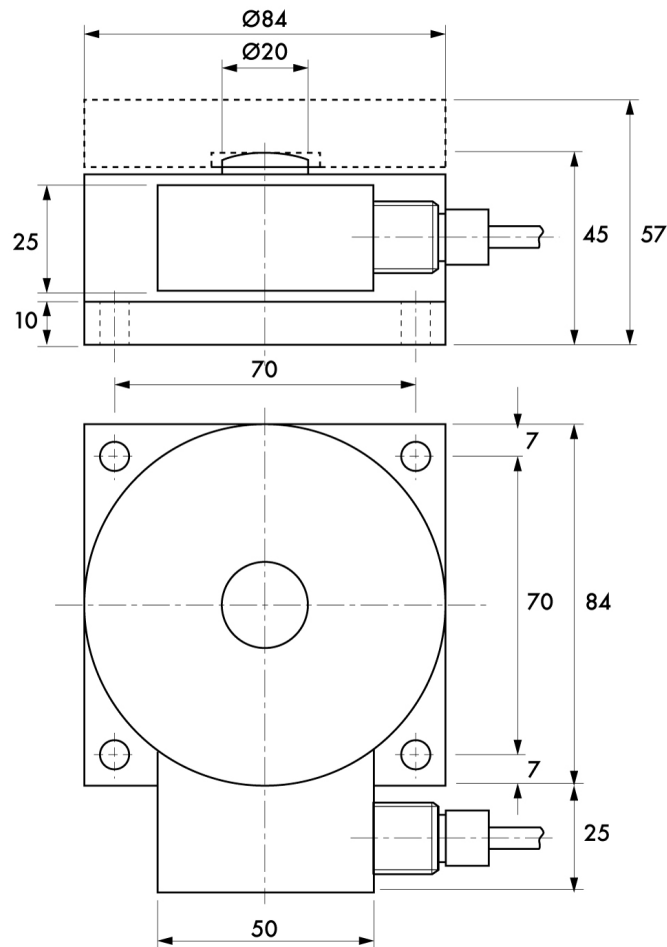

All indicated data may be changed without notice.
 All the measures indicated are expressed in millimeters (mm).

