

Technical specification sheet

PA 18 H 2 | Hand Pump

Specifications		
article number		100.142.035
short description		Hand Pump
model		PA 18 H 2
max. working pressure	bar/Mpa	720 / 72
capacity oil tank (effective)	cc	1800
capacity oil tank	cc	1990
number of stages		2
first stage output (per stroke)	cc	42.8
second stage output (per stroke)	cc	3.1
first stage pressure range	bar/Mpa	0 - 45 / 0 - 4.5
second stage pressure range	bar/Mpa	45 - 720 / 4.5 - 72
max. operating force	kg	35.0
connection		3/8" NPT female
operator type		hand
double acting optional		yes
weight, ready for use	kg	7.6

Technical drawing dimensions		
dimension A	mm	700
dimension B	mm	169
dimension C	mm	175

Accessories		
Foot Plate Set For PA 18/38 Pumps		100.182.217
Double Acting Valve VM 43 L		100.182.175
Foot Plate Set For PA 18/38 pumps incl. VM 43 L Valve		100.182.219
Pressure Gauge Set For Valve VM 43 L		100.182.216

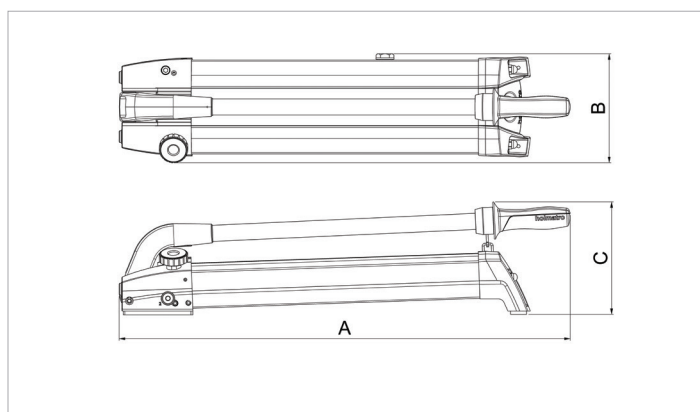

holmatro.com

© Holmatro 2021-09-03

While the greatest care has been devoted to the content, it is possible that the information in this printed matter is incorrect or incomplete. Holmatro B.V. and its affiliated companies (hereafter: Holmatro) cannot be held liable in any way for the consequences of activities undertaken on the basis of this printed matter. Values can vary within the manufacturer measurements. If you have any doubts about the correctness or completeness of the information, you shall contact Holmatro (T +31 (0)162-751480). Nothing from this printed matter can be copied and/or made public in any way without the explicit authorisation of Holmatro.