

 Aliaxis



pen



VM DN 80÷100

PVC-U

Diaphragm valve

VM DN 80÷100

The VM is particularly suitable for shutting off and regulating abrasive or dirty fluids. The handwheel control and diaphragm seal provide precise and effective control, while reducing the risk of water hammer to a minimum.

DIAPHRAGM VALVE

- Connection system for solvent welding and for flanged joints
- **Optimised fluid dynamic design:** maximum output flow rate thanks to the optimised efficiency of the fluid dynamics that characterise the new internal geometry of the body
- Handwheel that stays at the same height during rotation, with internal bearing to minimise friction and operating torque
- Standard optical indicator
- **Internal operating components in metal** totally isolated from the conveyed fluid
- Bonnet fastening screws in STAINLESS steel protected against the external environment by PE plugs
- **New flanged bodies:** the new bodies, characterised by a monolithic flanged structure, are available in PVC-U, PVC-C, PP-H and PVDF. This design, free from body and flange joints, greatly reduces mechanical stress and increases system performance.

Technical specifications	
Construction	Single wear diaphragm valve
Size range	DN 80 ÷ 100
Nominal pressure	PN 10 with water at 20° C PN 6 with water at 20° C (PTFE version)
Temperature range	0 °C ÷ 60 °C
Coupling standards	Solvent welding: EN ISO 1452, EN ISO 15493, BS 4346-1, DIN 8063, NF T54-028, ASTM D 2467, JIS K 6743. Can be coupled to pipes according to EN ISO 1452, EN ISO 15493. Flanging system: ISO 7005-1, EN ISO 1452, EN ISO 15493, EN 558-1, DIN 2501, ANSI B.16.5 cl. 150.
Reference standards	Construction criteria: EN ISO 16138, EN ISO 1452, EN ISO 15493 Test methods and requirements: ISO 9393 Installation criteria: DVS 2204, DVS 2221, UNI 11242
Valve material	Body: PVC-U Bonnet: PP-GR Handwheel: PA-GR
Seal material	EPDM, FKM, PTFE (on request NBR)
Control options	Manual control; pneumatic actuator



- 1 Handwheel** in (PA-GR) with high mechanical strength and ergonomic **grip for optimum manageability**
- 2 Metal optical position indicator** supplied as standard
- 3 Full protection bonnet** in PP-GR Internal circular and symmetrical diaphragm sealing area
- 4 Diaphragm** available in EPDM, FPM, PTFE (NBR on request) and easy to replace
- 5 Threaded metal inserts** for anchoring the valve
- 6 New valve body internal design** substantially higher flow coefficient resulting in lower pressure drops. Optimised adjustment curve for effective and precise flow rate regulation

TECHNICAL DATA

PRESSURE VARIATION ACCORDING TO TEMPERATURE

For water and non-hazardous fluids with regard to which the material is classified as CHEMICALLY RESISTANT. In other cases, a reduction of the nominal pressure PN is required (25 years with safety factor).



PRESSURE DROP GRAPH

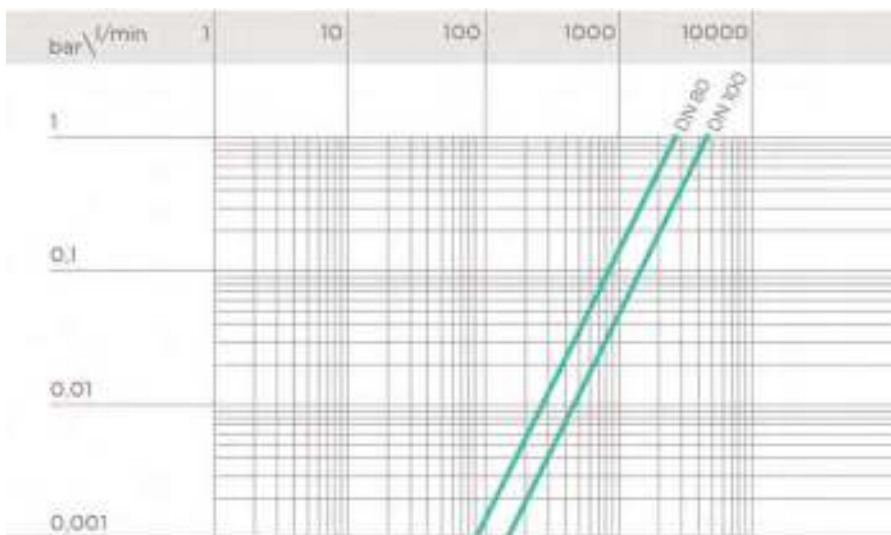

K_v100 FLOW COEFFICIENT

The K_v100 flow coefficient is the Q flow rate of litres per minute of water at a temperature of 20°C that will generate Δp= 1 bar pressure drop at a certain valve position. The Kv100 values shown in the table are calculated with the valve completely open.

DN	80	100
Kv100 l/min	2910	4620

The information in this leaflet is provided in good faith. No liability will be accepted concerning technical data that is not directly covered by recognised international standards. FIP reserves the right to carry out any modification. Products must be installed and maintained by qualified personnel.

DIMENSIONS



VMDV

Diaphragm valve with male ends for solvent welding, metric series

d	DN	PN	B	B1	H	H1	h	I	J	L	g	EPDM code	FKM code	PTFE code
90	80	*10	225	55	300	200	23	100	M12	51	7000	VMDV090E	VMDV090F	VMDV090P
110	100	*10	295	69	340	250	23	120	M12	61	10500	VMDV110E	VMDV110F	VMDV110P

*PTFE PN6

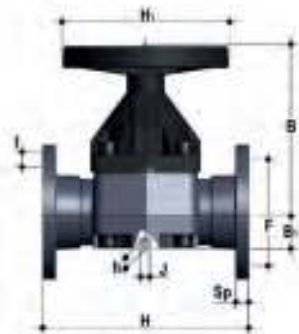

VMOV

Diaphragm valve with flanged monolithic body, drilled PN10/16. Face to face according to EN 558-1

d	DN	PN	B	B1	F	f	H	H1	I	J	Sp	U	g	EPDM code	FKM code	PTFE code
90	80	*10	225	64	160	18	310	200	100	M12	21,5	8	8500	VMOV090E	VMOV090F	VMOV090P
110	100	*10	295	72	180	18	350	250	120	M12	22,5	8	12400	VMOV110E	VMOV110F	VMOV110P

*PTFE PN6

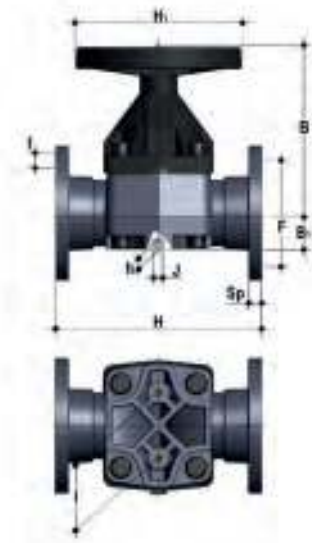

VMOAV

Diaphragm valve with flanged monolithic body, drilled ANSI B16.5 cl. 150 #FF

d	DN	PN	B	B1	F	f	H	H1	I	J	Sp	U	g	EPDM code	FKM code	PTFE code
3"	80	*10	225	64	152,4	19,1	263	200	100	M12	21,5	4	8500	VMOAV300E	VMOAV300F	VMOAV300P
4"	100	*10	295	72	190,5	19,1	328	250	120	M12	22,5	8	12400	VMOAV400E	VMOAV400F	VMOAV400P

* PTFE: PN 6

For installation prior to october 2017 please contact Fip Technical Support