

DOUBLE-PISTON QUARTER TURN ACTUATORS

TYPE SAD-HD / SAF-HD 90°

Technical Data

Design :	Pneumatic double-piston quarter turn actuator with hydraulic damping
Design features :	Rack-and-pinion system, piston guide via guide rods Adjustable operating times to avoid pressure impacts in the piping system Operating time independent from working pressure
Angle of rotation :	0°-90°, also available in 135°
Air pressure supply :	mind. 2 bar, max. 8 bar
Operating medium :	Dry and filtered compressed air
Ambient temperature :	-25°C to +80°C
Mounting position :	any
Resistance to corrosion :	Industrial atmosphere
Lubrication :	Life time lubrication with grease ISO 51825-K2K-30
Seals :	NBR-O-Rings, 70 Shore
Coatings :	Housing anodized and colour sealed End caps - CED Cathodic electrodeposition
Maintenance and inspection :	AMG actuators are free of maintenance within the life time. Provided that: <ul style="list-style-type: none">• the actuator is properly mounted• the operating medium used is clean and non-aggressive• the actuator is operated under normal ambient conditions• the actuator is used in compliance with the intended use (see assembly and maintenance manual)
Applied standard:	DIN EN ISO 5211, DIN EN 15714-3, VDI / VDE 3845, DIN 79



SAF-HD

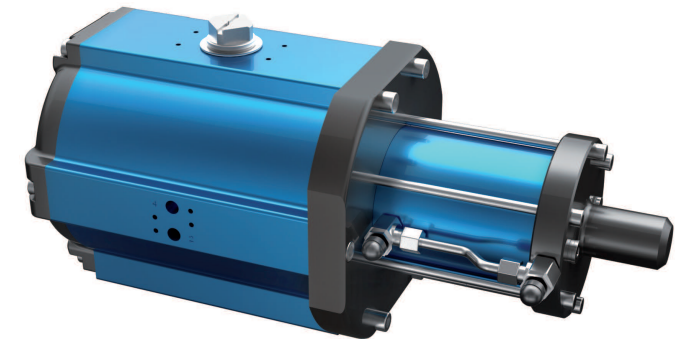

SAD-HD

AMG-PESCH®



an **BRUKS** company

AMG-PESCH GmbH
Adam-Riese-Straße 1
D - 50996 Köln
Tel.: +49-(0) 22 36 - 89 16 - 0
Fax: +49-(0) 22 36 - 89 16 - 73
info@amg-pesch.com
www.amg-pesch.com

DOUBLE-PISTON QUARTER TURN ACTUATORS
TYPE SAD-HD / SAF-HD 90°

Size	40
Weight [kg]	
Type SAD-HD	33
Type SAF-HD	44
Stroke volume [dm ³]	
Type SAD-HD	10,6
Type SAF-HD	6,1
Operating times [sec.] ¹⁾	
Type SAD-HD OPEN	4
Type SAD-HD CLOSE	5
Type SAF-HD ²⁾ OPEN	6
Type SAF-HD ²⁾ CLOSE	3

1) operating times at 4,5 bar air pressure supply without load (standard values)

2) Type SAF-HD with 9 springs

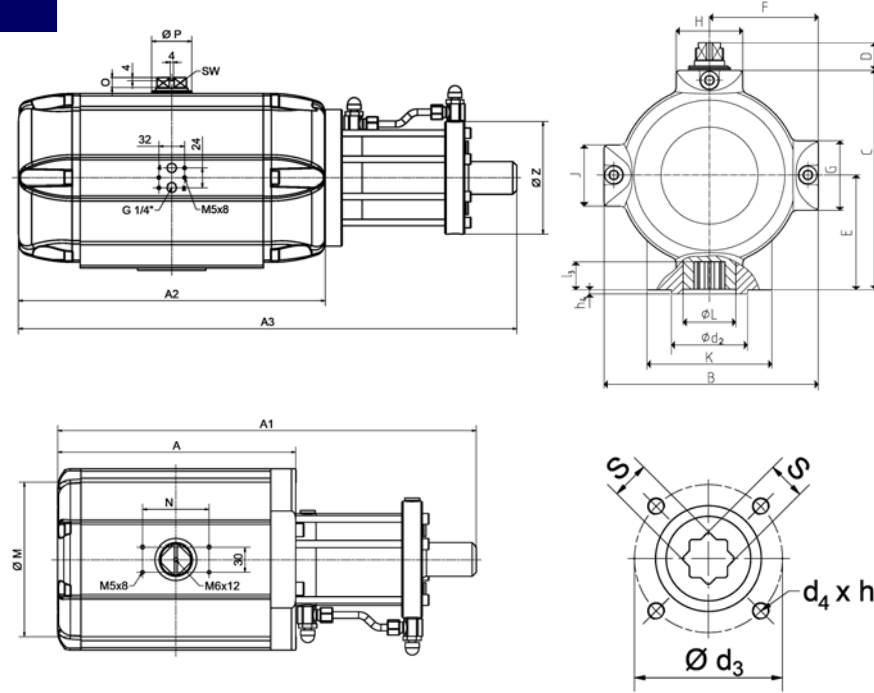

Type	number of springs n	spring-torque		air torque Ma [Nm] at operating pressure pe [bar]																											
		Ms [Nm]		2 bar		2,5 bar		3 bar		3,5 bar		4 bar		4,5 bar		5 bar		5,5 bar		6 bar		6,5 bar		7 bar		7,5 bar		8 bar			
		MIN	MAX	MIN	MAX	MIN	MAX	MIN	MAX	MIN	MAX	MIN	MAX	MIN	MAX	MIN	MAX	MIN	MAX	MIN	MAX	MIN	MAX	MIN	MAX	MIN	MAX	MIN	MAX		
SAD-HD 40	-	-	-	336		435		534		629		727		827		924		1022		1121		1220		1314		1408		1502			
SAF-HD 40	4	133	222	114	203	213	302	312	401	407	496	505	594	605	694	702	791	800	889	899	988	998	1087	1092	1181	1186	1275	1280	1369		
	5	166	277	59	170	158	269	257	368	352	463	450	561	550	661	647	758	745	856	844	955	943	1054	1037	1148	1131	1242	1225	1336		
	6	199	333	3	137	102	236	201	335	296	430	394	528	494	628	591	725	689	823	788	922	887	1021	981	1115	1075	1209	1169	1303		
	7	232	388			47	203	146	302	241	397	339	495	439	595	536	692	634	790	733	889	832	988	926	1082	1020	1176	1114	1270		
	8	266	443					91	268	186	363	284	461	384	561	481	658	579	756	678	855	777	954	871	1048	965	1142	1059	1236		
	9	299	499					35	235	130	330	228	428	328	528	425	625	523	723	622	822	721	921	815	1015	909	1109	1003	1203		
	10	332	554							75	297	173	395	273	495	370	592	468	690	567	789	666	888	760	982	854	1076	948	1170		
	11	365	610							19	264	117	362	217	462	314	559	412	657	511	756	610	855	704	949	798	1043	892	1137		
	12	398	665									62	329	162	429	259	526	357	624	456	723	555	822	649	916	743	1010	837	1104		

Design	SAD-HD / SAF-HD
Size	40
A / A1 (double-acting)	293 / 510
A2 / A3 (single-acting)	428 / 667
B	268
C	266
D	20
E	136
F	134
G	60
H	108
K	125
Ø L	62
J	60
Ø M	236
N	80
O	12
Ø P	50
Ø Z	140
SW	30
Connection ISO 5211	F14
Ø d ₂	100
Ø d ₃	140
d ₄ x h ₃	M16x25
Number of screws	4
h ₄	4
l ₃	40
s	36

AMG-PESCH®



an ERIKS company

AMG-PESCH GmbH
 Adam-Riese-Straße 1
 D - 50996 Köln
 Tel.: +49-(0) 22 36 - 89 16 - 0
 Fax: +49-(0) 22 36 - 89 16 - 73
info@amg-pesch.com
www.amg-pesch.com