

DOUBLE-PISTON QUARTER TURN ACTUATORS

TYPE BR16 SAD / SAF 90°

Technical Data

Design :	Pneumatic double-piston quarter turn actuator
Design features :	Rack-and-pinion system, piston guide via guide rods
Angle of rotation :	0°-90°
Air pressure supply :	mind. 2 bar, max. 10 bar
Operating medium :	Dry and filtered compressed air
Ambient temperature :	-25°C to +80°C
Mounting position :	any
Resistance to corrosion :	Industrial atmosphere
Lubrication :	Life time lubrication with grease ISO 51825-K2K-30
Seals :	NBR-O-Rings, 70 Shore
Coatings :	Housing anodized and colour sealed End caps - CED cathodic electrodeposition
Maintenance and inspection :	AMG actuators are free of maintenance within the life time. Provided that: <ul style="list-style-type: none"> • the actuator is properly mounted • the operating medium used is clean and non-aggressive • the actuator is operated under normal ambient conditions • the actuator is used in compliance with the intended use (see assembly and maintenance manual)
Applied standard:	DIN EN ISO 5211, DIN EN 15714-3, VDI / VDE 3845, DIN 79
Options:	Extended angle of rotation 120°, 135°, 180° Adjustable inner / outer travel stops up to +/- 5° via travel-stop-module (TSM) Ambient temperature up to +100°C Ambient temperature down to -40°C Sealing elements made of FKM (viton) or alternatively fluorosilicone Tailor made mounting kits and dimensioning acc. To customer requirements Variable cycle times (fast / slow) Variable sens of rotation (clockwise / counterclockwise) Coating options: Hard-Coat, chemical nickelplating, plastic coating, special lacquer

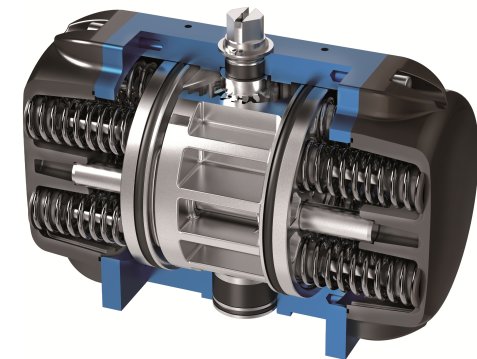

SAF

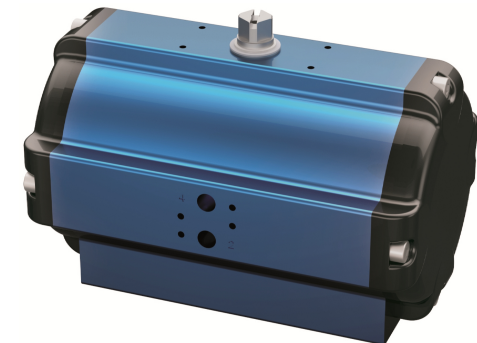

SAD

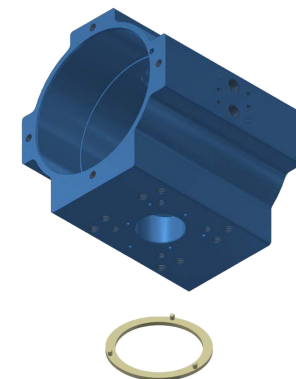



DOUBLE-PISTON QUARTER TURN ACTUATORS
TYPE BR16 SAD / SAF 90°

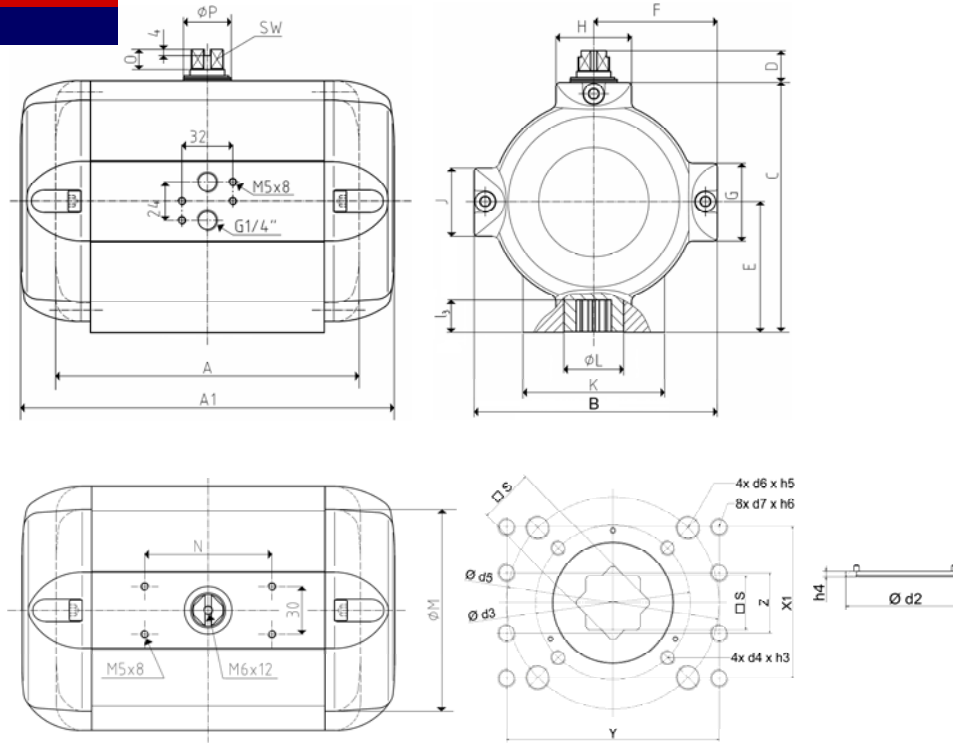

Size	40	
Weight [kg]		
Type SAD	24,0	
Type SAF	37,5	
Stroke volume [dm³]		
Type SAD	10,6	
Type SAF	6,1	
Operating times [sec.] ¹⁾		
Type SAD OPEN	1,5	
Type SAD CLOSE	1,5	
Type SAF ²⁾ OPEN	3,0	
Type SAF ²⁾ CLOSE	1,5	

1) operating times at 4,5 bar air pressure supply without load (standard values)

2) Type SAF with 9 springs

Type	number of springs n	spring-torque		air torque Ma [Nm] at operating pressure pe [bar]																									
		Ms [Nm]		2 bar		2,5 bar		3 bar		3,5 bar		4 bar		4,5 bar		5 bar		5,5 bar		6 bar		6,5 bar		7 bar		7,5 bar		8 bar	
		MIN	MAX	MIN	MAX	MIN	MAX	MIN	MAX	MIN	MAX	MIN	MAX	MIN	MAX	MIN	MAX	MIN	MAX	MIN	MAX	MIN	MAX	MIN	MAX	MIN	MAX	MIN	MAX
SAD 40	-	-	-	336		435		534		629		727		827		924		1022		1121		1220		1314		1408		1502	
SAF 40	4	133	222	114	203	213	302	312	401	407	496	505	594	605	694	702	791	800	889	899	988	998	1087	1092	1181	1186	1275	1280	1369
	5	166	277	59	170	158	269	257	368	352	463	450	561	550	661	647	758	745	856	844	955	943	1054	1037	1148	1131	1242	1225	1336
	6	199	333	3	137	102	236	201	335	296	430	394	528	494	628	591	725	689	823	788	922	887	1021	981	1115	1075	1209	1169	1303
	7	232	388			47	203	146	302	241	397	339	495	439	595	536	692	634	790	733	889	832	988	926	1082	1020	1176	1114	1270
	8	266	443					91	268	186	363	284	461	384	561	481	658	579	756	678	855	777	954	871	1048	965	1142	1059	1236
	9	299	499					35	235	130	330	228	428	328	528	425	625	523	723	622	822	721	921	815	1015	909	1109	1003	1203
	10	332	554							75	297	173	395	273	495	370	592	468	690	567	789	666	888	760	982	854	1076	948	1170
	11	365	610							19	264	117	362	217	462	314	559	412	657	511	756	610	855	704	949	798	1043	892	1137
	12	398	665									62	329	162	429	259	526	357	624	456	723	555	822	649	916	743	1010	837	1104
	special version																												
13	432	719									8	295	108	395	205	492	303	590	402	689	501	788	595	882	689	976	783	1070	
14	465	776											51	362	148	459	246	557	345	656	444	755	538	849	632	943	726	1037	

Design	SAD / SAF	
Size	40	
A (double-acting)	318	
A1 (single-acting)	430	
B	268	
C	266	
D	20	
E	136	
F	134	
G	60	
H	108	
K	125	
Ø L	62	
J	60	
Ø M	236	
N	80	
O	12	
Ø P	50	
SW	30	
Connection ISO 5211	F14	F10
Ø d2	100	-
h4	3	-
Ø d3	102	
4x d4xh3	4x M10x16	
Ø d5	140	
l ₃	40	
s	36	
4x d6xh5	4x M16x25	
8x d7xh6	8x M12x18	
Y	140	
Z	40	
W1	-	
X1	100	
G1	-	