

## DOUBLE-PISTON QUARTER TURN ACTUATORS

### TYPE BR16 SAD / SAF 90°

#### Technical Data

<b>Design :</b>	Pneumatic double-piston quarter turn actuator
<b>Design features :</b>	Rack-and-pinion system, piston guide via guide rods
<b>Angle of rotation :</b>	0°-90°
<b>Air pressure supply :</b>	mind. 2 bar, max. 10 bar
<b>Operating medium :</b>	Dry and filtered compressed air
<b>Ambient temperature :</b>	-25°C to +80°C
<b>Mounting position :</b>	any
<b>Resistance to corrosion :</b>	Industrial atmosphere
<b>Lubrication :</b>	Life time lubrication with grease ISO 51825-K2K-30
<b>Seals :</b>	NBR-O-Rings, 70 Shore
<b>Coatings :</b>	Housing anodized and colour sealed End caps - CED cathodic electrodeposition
<b>Maintenance and inspection :</b>	AMG actuators are free of maintenance within the life time. Provided that: <ul style="list-style-type: none"> <li>• the actuator is properly mounted</li> <li>• the operating medium used is clean and non-aggressive</li> <li>• the actuator is operated under normal ambient conditions</li> <li>• the actuator is used in compliance with the intended use (see assembly and maintenance manual)</li> </ul>
<b>Applied standard:</b>	DIN EN ISO 5211, DIN EN 15714-3, VDI / VDE 3845, DIN 79
<b>Options:</b>	Extended angle of rotation 120°, 135°, 180° Adjustable inner / outer travel stops up to +/- 5° via travel-stop-module (TSM) Ambient temperature up to +100°C Ambient temperature down to -40°C Sealing elements made of FKM (viton) or alternatively fluorosilicone Tailor made mounting kits and dimensioning acc. To customer requirements Variable cycle times (fast / slow) Variable sens of rotation (clockwise / counterclockwise) Coating options: Hard-Coat, chemical nickelplating, plastic coating, special lacquer

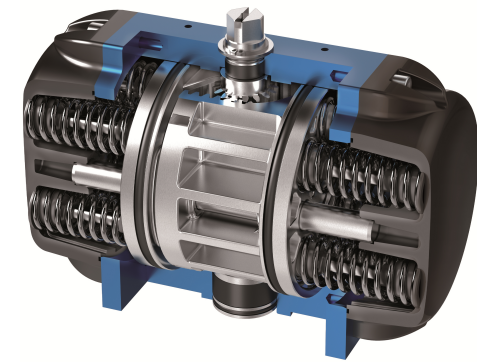

SAF

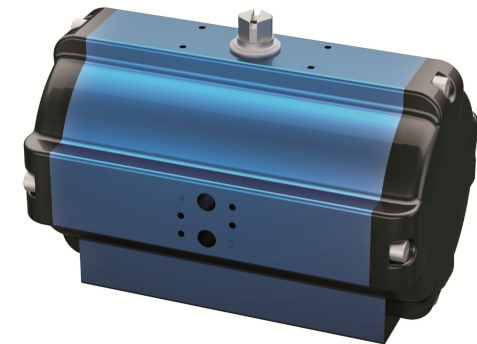

SAD

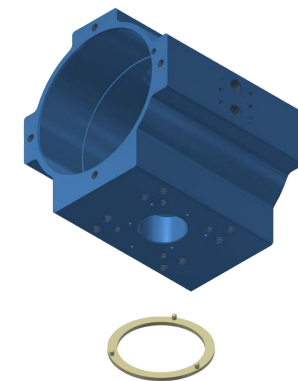



**DOUBLE-PISTON QUARTER TURN ACTUATORS**  
**TYPE BR16 SAD / SAF 90°**

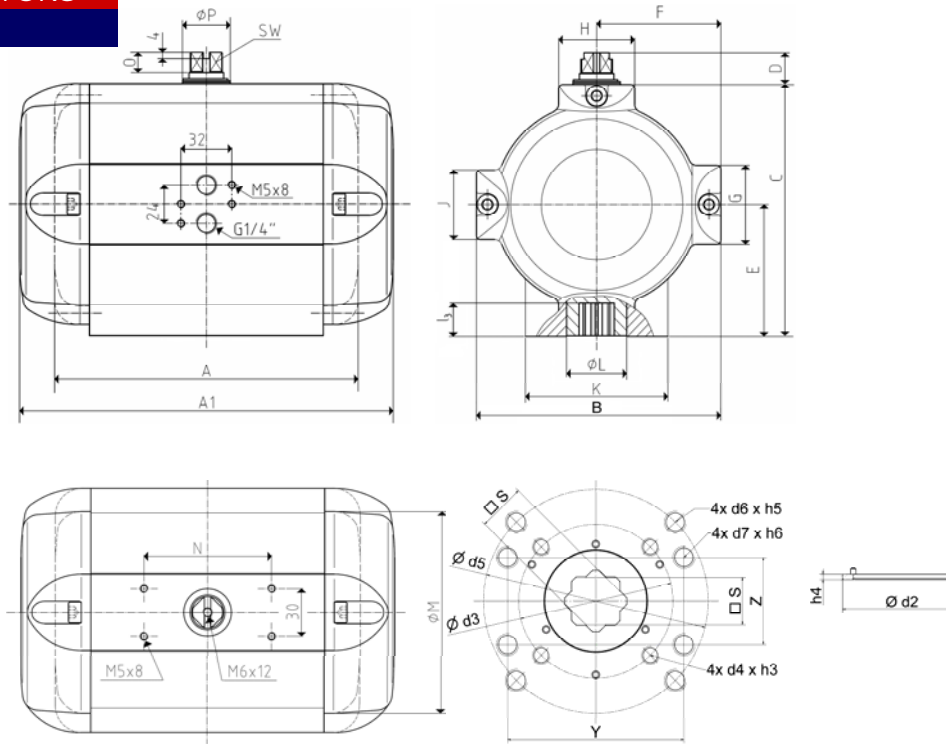

Size	25	
Weight [kg]		
Type SAD	6,0	
Type SAF	8,5	
Stroke volume [dm³]		
Type SAD	2,0	
Type SAF	1,0	
Operating times [sec.] <sup>1)</sup>		
Type SAD OPEN	0,4	
Type SAD CLOSE	0,4	
Type SAF <sup>2)</sup> OPEN	0,4	
Type SAF <sup>2)</sup> CLOSE	0,2	

1) operating times at 4,5 bar air pressure supply without load (standard values)

2) Type SAF with 9 springs

Type	number of springs n	spring-torque Ms [Nm]	air torque Ma [Nm] at operating pressure pe [bar]																											
			2 bar		2,5 bar		3 bar		3,5 bar		4 bar		4,5 bar		5 bar		5,5 bar		6 bar		6,5 bar		7 bar		7,5 bar		8 bar			
			MIN	MAX	MIN	MAX	MIN	MAX	MIN	MAX	MIN	MAX	MIN	MAX	MIN	MAX	MIN	MAX	MIN	MAX	MIN	MAX	MIN	MAX	MIN	MAX	MIN	MAX	MIN	MAX
SAD 25	-	-	61, 79, 98, 115, 133, 151, 169, 187, 205, 223, 240, 257, 275																											
SAF 25	4	24,2 40,2	20,8 36,8	38,8 54,8	57,8 73,8	74,8 90,8	92,8 108,8	110,8 126,8	128,8 144,8	146,8 162,8	164,8 180,8	182,8 198,8	199,8 215,8	216,8 232,8	234,8 250,8															
	5	30,2 50,2	10,8 30,8	28,8 48,8	47,8 67,8	64,8 84,8	82,8 102,8	100,8 120,8	118,8 138,8	136,8 156,8	154,8 174,8	172,8 192,8	189,8 209,8	206,8 226,8	224,8 244,8															
	6	36,3 60,2	0,8 24,7	18,8 42,7	37,8 61,7	54,8 78,7	72,8 96,7	90,8 114,7	108,8 132,7	126,8 150,7	144,8 168,7	162,8 186,7	179,8 203,7	196,8 220,7	214,8 238,7															
	7	42,3 70,3		8,7 36,7	27,7 55,7	44,7 72,7	62,7 90,7	80,7 108,7	98,7 126,7	116,7 144,7	134,7 162,7	152,7 180,7	169,7 197,7	186,7 214,7	204,7 232,7															
	8	48,3 80,3			17,7 49,7	34,7 66,7	52,7 84,7	70,7 102,7	88,7 120,7	106,7 138,7	124,7 156,7	142,7 174,7	159,7 191,7	176,7 208,7	194,7 226,7															
	9	54,4 90,4			7,6 43,6	24,6 60,6	42,6 78,6	60,6 96,6	78,6 114,6	96,6 132,6	114,6 150,6	132,6 168,6	149,6 185,6	166,6 202,6	184,6 220,6															
	10	60,4 100,4				14,6 54,6	32,6 72,6	50,6 90,6	68,6 108,6	86,6 126,6	104,6 144,6	122,6 162,6	139,6 179,6	156,6 196,6	174,6 214,6															
	11	66,5 110,8				4,2 48,5	22,2 66,5	40,2 84,5	58,2 102,5	76,2 120,5	94,2 138,5	112,2 156,5	129,2 173,5	146,2 190,5	164,2 208,5															
	12	72,5 120,5					12,5 60,5	30,5 78,5	48,5 96,5	66,5 114,5	84,5 132,5	102,5 150,5	119,5 167,5	136,5 184,5	154,5 202,5															
	special version																													
13	78,6 131,0					2,0 54,4	20,0 72,4	38,0 90,4	56,0 108,4	74,0 126,4	92,0 144,4	109,0 161,4	126,0 178,4	144,0 196,4																
14	84,6 141,0						10,0 66,4	28,0 84,4	46,0 102,4	64,0 120,4	82,0 138,4	99,0 155,4	116,0 172,4	134,0 190,4																

Design	SAD / SAF	
Size	25	
A (double-acting)	191	
A1 (single-acting)	235	
B	154,5	
C	159	
D	20	
E	83	
F	78,5	
G	50	
H	48	
K	90	
Ø L	38	
J	44	
Ø M	130	
N	80	
O	12	
Ø P	30	
SW	17	
Connection ISO 5211	F07	F10
Ø d2	55	70
h4	2,5	2,5
Ø d3	70	
4x d4xh3	4x M8x13	
Ø d5	102	
l <sub>3</sub>	20	
s	17	
4x d6xh5	4x M10x16	
4x d7xh6	4x M10x16	
Y	80	
Z	40	
W1	-	
X1	-	
G1	-	