

Technical Data

Design :	Pneumatic double-piston quarter turn actuator
Design features :	Rack-and-pinion system, piston guide via guide rods
Angle of rotation :	0°-90°
Air pressure supply :	mind. 2 bar, max. 10 bar
Operating medium :	Dry and filtered compressed air
Ambient temperature :	-25°C to +80°C
Mounting position :	any
Resistance to corrosion :	Industrial atmosphere
Lubrication :	Life time lubrication with grease ISO 51825-K2K-30
Seals :	NBR-O-Rings, 70 Shore
Coatings :	Housing anodized and colour sealed End caps - CED cathodic electrodeposition
Maintenance and inspection :	AMG actuators are free of maintenance within the life time. Provided that: <ul style="list-style-type: none"> • the actuator is properly mounted • the operating medium used is clean and non-aggressive • the actuator is operated under normal ambient conditions • the actuator is used in compliance with the intended use (see assembly and maintenance manual)
Applied standard:	DIN EN ISO 5211, DIN EN 15714-3, VDI / VDE 3845, DIN 79
Options:	Extended angle of rotation 120°, 135°, 180° Adjustable inner / outer travel stops up to +/- 5° via travel-stop-module (BR03C-DE) Ambient temperature up to +100°C (BR03C-HT Version) Ambient temperature down to -40°C (BR03C-TT Version) Sealing elements made of FKM (viton) or alternatively fluorosilicone Tailor made mounting kits and dimensioning acc. To customer requirements Variable cycle times (fast / slow) Variable sens of rotation (clockwise / counterclockwise) Coating options: Hard-Coat, chemical nickelplating, plastic coating, special lacquer



SAF

SAD

Size	25	
Weight [kg]		
Type SAD	6,0	
Type SAF	8,5	
Stroke volume [dm³]		
Type SAD	2,0	
Type SAF	1,0	
Operating times [sec.] ¹⁾		
Type SAD OPEN	0,4	
Type SAD CLOSE	0,4	
Type SAF ²⁾ OPEN	0,4	
Type SAF ²⁾ CLOSE	0,2	

1) operating times at 4,5 bar air pressure supply without load (standard values)

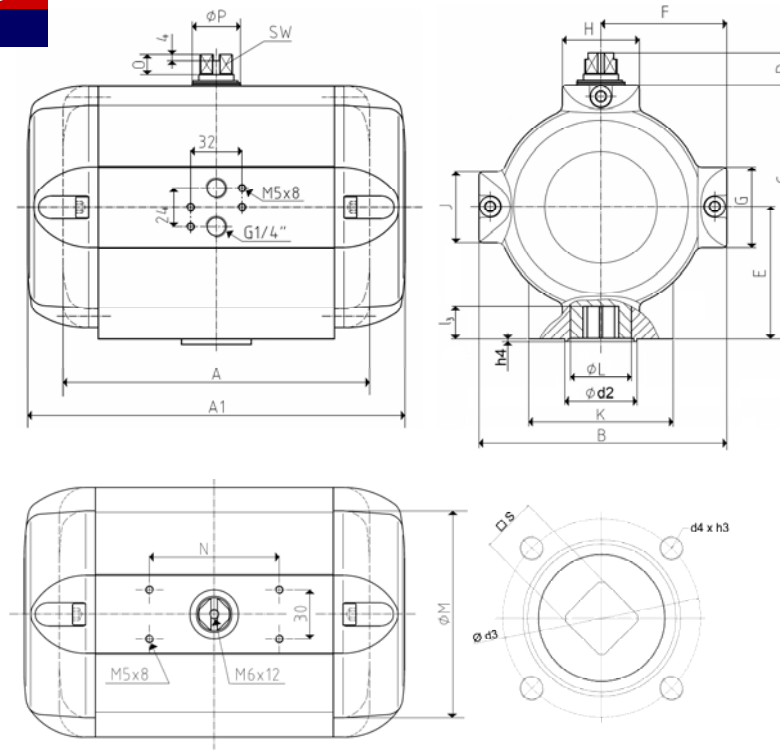
2) Type SAF with 9 springs



Design	SAD / SAF
Size	25
A (double-acting)	191
A1 (single-acting)	235
B	154,5
C	159
D	20
E	83
F	78,5
G	50
H	48
K	90
Ø L	38
J	44
Ø M	130
N	80
O	12
Ø P	30
SW	17
Connection ISO 5211	F07
Ø d ₂	55
Ø d ₃	70
d ₄ x h ₃	M8x13
number of bolts	4
h ₄	3
l ₃	20
s	17

Type	number of springs n	spring-torque		air torque Ma [Nm] at operating pressure pe [bar]																											
		Ms [Nm]		2 bar		2,5 bar		3 bar		3,5 bar		4 bar		4,5 bar		5 bar		5,5 bar		6 bar		6,5 bar		7 bar		7,5 bar		8 bar			
		MIN	MAX	MIN	MAX	MIN	MAX	MIN	MAX	MIN	MAX	MIN	MAX	MIN	MAX	MIN	MAX	MIN	MAX	MIN	MAX	MIN	MAX	MIN	MAX	MIN	MAX	MIN	MAX		
SAD 25	-	-		61		79		98		115		133		151		169		187		205		223		240		257		275			
SAF 25	4	24,2	40,2	20,8	36,8	38,8	54,8	57,8	73,8	74,8	90,8	92,8	108,8	110,8	126,8	128,8	144,8	146,8	162,8	164,8	180,8	182,8	198,8	199,8	215,8	216,8	232,8	234,8	250,8		
	5	30,2	50,2	10,8	30,8	28,8	48,8	47,8	67,8	64,8	84,8	82,8	102,8	100,8	120,8	118,8	138,8	136,8	156,8	154,8	174,8	172,8	192,8	189,8	209,8	206,8	226,8	224,8	244,8		
	6	36,3	60,2	0,8	24,7	18,8	42,7	37,8	61,7	54,8	78,7	72,8	96,7	90,8	114,7	108,8	132,7	126,8	150,7	144,8	168,7	162,8	186,7	179,8	203,7	196,8	220,7	214,8	238,7		
	7	42,3	70,3			8,7	36,7	27,7	55,7	44,7	72,7	62,7	90,7	80,7	108,7	98,7	126,7	116,7	144,7	134,7	162,7	152,7	180,7	169,7	197,7	186,7	214,7	204,7	232,7		
	8	48,3	80,3					17,7	49,7	34,7	66,7	52,7	84,7	70,7	102,7	88,7	120,7	106,7	138,7	124,7	156,7	142,7	174,7	159,7	191,7	176,7	208,7	194,7	226,7		
	9	54,4	90,4					7,6	43,6	24,6	60,6	42,6	78,6	60,6	96,6	78,6	114,6	96,6	132,6	114,6	150,6	132,6	168,6	149,6	185,6	166,6	202,6	184,6	220,6		
	10	60,4	100,4							14,6	54,6	32,6	72,6	50,6	90,6	68,6	108,6	86,6	126,6	104,6	144,6	122,6	162,6	139,6	179,6	156,6	196,6	174,6	214,6		
	11	66,5	110,8							4,2	48,5	22,2	66,5	40,2	84,5	58,2	102,5	76,2	120,5	94,2	138,5	112,2	156,5	129,2	173,5	146,2	190,5	164,2	208,5		
	12	72,5	120,5									12,5	60,5	30,5	78,5	48,5	96,5	66,5	114,5	84,5	132,5	102,5	150,5	119,5	167,5	136,5	184,5	154,5	202,5		
	Sonderausführung																														
	13	78,6	131,0								2,0	54,4	20,0	72,4	38,0	90,4	56,0	108,4	74,0	126,4	92,0	144,4	109,0	161,4	126,0	178,4	144,0	196,4			
	14	84,6	141,0										10,0	66,4	28,0	84,4	46,0	102,4	64,0	120,4	82,0	138,4	99,0	155,4	116,0	172,4	134,0	190,4			