



DOUBLE-PISTON QUARTER TURN ACTUATORS

TYPE BR03 SADT / SADP 90°

Technical Data

Design :	SADT: Pneumatic double acting quarter turn actuator with tandem pistons for high torques SADP: Pneumatic double acting quarter turn actuator with spring return function
Design features :	Rack-and-pinion system, piston guide via guide rods
Angle of rotation :	0°-90°
Air pressure supply :	mind. 2 bar, max. 6 bar
Operating medium :	Dry and filtered compressed air
Ambient temperature :	-25°C to +80°C
Mounting position :	any
Resistance to corrosion :	Industrial atmosphere
Lubrication :	Life time lubrication with grease ISO 51825-K2K-30
Seals :	NBR-O-Rings, 70 Shore
Coatings :	Housing anodized and colour sealed End caps - CED Cathodic electrodeposition
Maintenance and inspection :	AMG actuators are free of maintenance within the life time. Provided that: <ul style="list-style-type: none"> • the actuator is properly mounted • the operating medium used is clean and non-aggressive • the actuator is operated under normal ambient conditions • the actuator is used in compliance with the intended use <small>(see assembly and maintenance manual)</small>
Applied standards :	DIN EN ISO 5211, DIN EN 15714-3, VDI / VDE 3845, DIN 79
Options:	Adjustable inner / outer travel stops up to +/- 5° via travel-stop-module (TSM) Ambient temperature up to +100°C Ambient temperature down to -40°C Sealing elements made of FKM (viton) or alternatively fluorosilicone Variable sens of rotation (clockwise / counterclockwise) Coating options: Hard-Coat, chemical nickelplating, plastic coating, special lacquer



SADT / SADP



DOUBLE-PISTON QUARTER TURN ACTUATORS
TYPE BR03 SADT / SADP 90°

Size	50-70	
Weight [kg]		
Type SADT	265	
Type SADP	320	
Stroke volume [dm ³]		
Type SADT	150	
Type SADP	54	
Operating times [sec.] ¹⁾		
Type SADT OPEN	45	
Type SADT CLOSE	55	
Type SADP ²⁾ OPEN	30	
Type SADP ²⁾ CLOSE	35	

1) operating times at 4,5 bar air pressure supply without load (standard values)

2) Type SADP with 25 springs

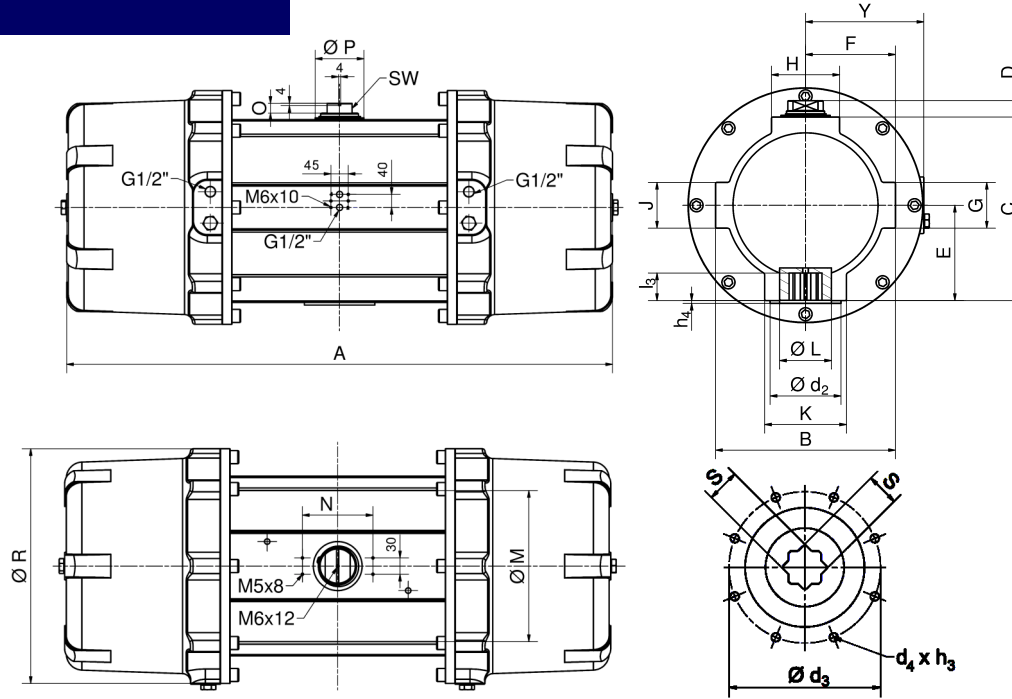

Design	SADT / SADP
Size	50-70
A	1218
B	390
C	389
D	30
E	197
F	195
G	84
H	150
K	265
Ø L	132
J	84
Ø M	345
N	130
O	18
Ø P	110
Ø R	525
Y	257
SW	46
Connection ISO 5211	F25
Ø d ₂	200
Ø d ₃	254
d ₄ x h ₃	M16x25
Number of screws	8
h ₄	5
l ₃	60
s	55

Type	air supply pe [bar]	number of springs n	spring torque Ms [Nm]		air torque Ma [Nm] at operating pressure pe [bar]								
			MIN	MAX	2 bar	2,5 bar	3 bar	3,5 bar	4 bar	4,5 bar	5 bar	5,5 bar	6 bar
SADT 50-70	-	-	-		4763	5954	7144	8335	9526	10716	11907	13098	14288
SADP 50-70	2	10	1550	2590	1576	2039	2503	2952	3411	3879	4333	4729	5256
	2,5	13	2015	3367		2039	2503	2952	3411	3879	4333	4729	5256
	3	16	2480	4144			2503	2952	3411	3879	4333	4729	5256
	3,5	19	2945	4921				2952	3411	3879	4333	4729	5256
	4	22	3410	5698					3411	3879	4333	4729	5256
	4,5	25	3875	6475						3879	4333	4729	5256
	5	28	4340	7252							4333	4729	5256
	5,5	31	4805	8029								4729	5256
	6	34	5270	8806									5256