

DOUBLE-PISTON QUARTER TURN ACTUATORS

TYPE SAD-HD / SAF-HD 90°

Technical Data

Design :	Pneumatic double-piston quarter turn actuator with hydraulic damping
Design features :	Rack-and-pinion system, piston guide via guide rods Adjustable operating times to avoid pressure impacts in the piping system Operating time independent from working pressure
Angle of rotation :	0°-90°, also available in 135°
Air pressure supply :	mind. 2 bar, max. 8 bar
Operating medium :	Dry and filtered compressed air
Ambient temperature :	-25°C to +80°C
Mounting position :	any
Resistance to corrosion :	Industrial atmosphere
Lubrication :	Life time lubrication with grease ISO 51825-K2K-30
Seals :	NBR-O-Rings, 70 Shore
Coatings :	Housing anodized and colour sealed End caps - CED Cathodic electrodeposition
Maintenance and inspection :	AMG actuators are free of maintenance within the life time. Provided that: <ul style="list-style-type: none">• the actuator is properly mounted• the operating medium used is clean and non-aggressive• the actuator is operated under normal ambient conditions• the actuator is used in compliance with the intended use (see assembly and maintenance manual)
Applied standard:	DIN EN ISO 5211, DIN EN 15714-3, VDI / VDE 3845, DIN 79



SAF-HD

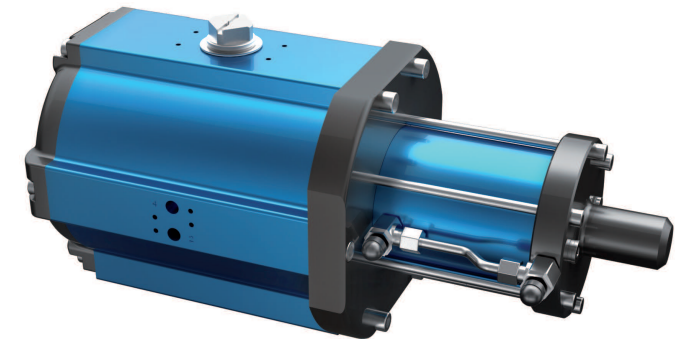

SAD-HD

AMG-PESCH®



an ERIKS company

AMG-PESCH GmbH
Adam-Riese-Straße 1
D - 50996 Köln
Tel.: +49-(0) 22 36 - 89 16 - 0
Fax: +49-(0) 22 36 - 89 16 - 73
info@amg-pesch.com
www.amg-pesch.com

DOUBLE-PISTON QUARTER TURN ACTUATORS
TYPE SAD-HD / SAF-HD 90°

Size	20
Weight [kg]	
Type SAD-HD	7,0
Type SAF-HD	8,0
Stroke volume [dm ³]	
Type SAD-HD	1,0
Type SAF-HD	0,5
Operating times [sec.] ¹⁾	
Type SAD-HD OPEN	1
Type SAD-HD CLOSE	1
Type SAF-HD ²⁾ OPEN	1
Type SAF-HD ²⁾ CLOSE	1

1) operating times at 4,5 bar air pressure supply without load (standard values)

2) Type SAF-HD with 9 springs

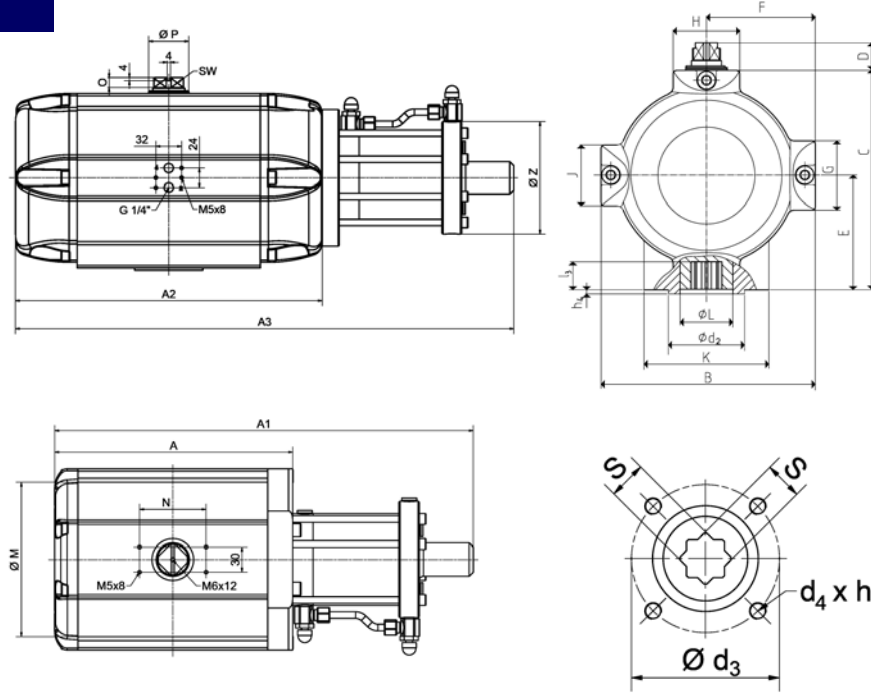

Type	number of springs n	spring-torque		air torque Ma [Nm] at operating pressure pe [bar]																											
		Ms [Nm]		2 bar		2,5 bar		3 bar		3,5 bar		4 bar		4,5 bar		5 bar		5,5 bar		6 bar		6,5 bar		7 bar		7,5 bar		8 bar			
		MIN	MAX	MIN	MAX	MIN	MAX	MIN	MAX	MIN	MAX	MIN	MAX	MIN	MAX	MIN	MAX	MIN	MAX	MIN	MAX	MIN	MAX	MIN	MAX	MIN	MAX	MIN	MAX		
SAD-HD 20	-	-	-	32	42	51	61	70	80	89	98	108	118	127	136	145															
SAF-HD 20	4	12,7	21,1	10,9	19,3	20,9	29,3	29,9	38,3	39,9	48,3	48,9	57,3	58,9	67,3	67,9	76,3	76,9	85,3	86,9	95,3	96,9	105,3	105,9	114,3	114,9	123,3	123,9	132,3		
	5	15,9	26,4	5,6	16,1	15,6	26,1	24,6	35,1	34,6	45,1	43,6	54,1	53,6	64,1	62,6	73,1	71,6	82,1	81,6	92,1	91,6	102,1	100,6	111,1	109,6	120,1	118,6	129,1		
	6	19,1	31,7			10,3	22,9	19,3	31,9	29,3	41,9	38,3	50,9	48,3	60,9	57,3	69,9	66,3	78,9	76,3	88,9	86,3	98,9	95,3	107,9	104,3	116,9	113,3	125,9		
	7	22,2	36,9			5,1	19,8	14,1	28,8	24,1	38,8	33,1	47,8	43,1	57,8	52,1	66,8	61,1	75,8	71,1	85,8	81,1	95,8	90,1	104,8	99,1	113,8	108,1	122,8		
	8	25,4	42,2					8,8	25,6	18,8	35,6	27,8	44,6	37,8	54,6	46,8	63,6	55,8	72,6	65,8	82,6	75,8	92,6	84,8	101,6	93,8	110,6	102,8	119,6		
	9	28,6	47,5					3,5	22,4	13,5	32,4	22,5	41,4	32,5	51,4	41,5	60,4	50,5	69,4	60,5	79,4	70,5	89,4	79,5	98,4	88,5	107,4	97,5	116,4		
	10	31,8	52,8						8,2	29,3	17,2	38,3	27,2	48,3	36,2	57,3	45,2	66,3	55,2	76,3	65,2	86,3	74,2	95,3	83,2	104,3	92,2	113,3			
	11	35,0	58,0						3,0	26,0	12,0	35,0	22,0	45,0	31,0	54,0	40,0	63,0	50,0	73,0	60,0	83,0	69,0	92,0	78,0	101,0	87,0	110,0			
	12	38,1	63,3							6,7	31,9	16,7	41,9	25,7	50,9	34,7	59,9	44,7	69,9	54,7	79,9	63,7	88,9	72,7	97,9	81,7	106,9				

Design	SAD-HD / SAF-HD
Size	20
A / A1 (double-acting)	157 / 326
A2 / A3 (single-acting)	210 / 387
B	134
C	132,5
D	20
E	68,5
F	70
G	50
H	48
K	64
Ø L	35
J	44
Ø M	111
N	80
O	12
Ø P	25
Ø Z	100
SW	14
Connection ISO 5211	F07
Ø d2	55
Ø d3	70
d4 x h3	M8x13
Number of screws	4
h4	3
l3	20
s	17

AMG-PESCH®



an ERIKS company

AMG-PESCH GmbH
 Adam-Riese-Straße 1
 D - 50996 Köln
 Tel.: +49-(0) 22 36 - 89 16 - 0
 Fax: +49-(0) 22 36 - 89 16 - 73
info@amg-pesch.com
www.amg-pesch.com