

Technical Data

Design :	Pneumatic double-piston quarter turn actuator
Design features :	Rack-and-pinion system, piston guide via guide rods
Angle of rotation :	0°-90°
Air pressure supply :	mind. 2 bar, max. 10 bar
Operating medium :	Dry and filtered compressed air
Ambient temperature :	-25°C to +80°C
Mounting position :	any
Resistance to corrosion :	Industrial atmosphere
Lubrication :	Life time lubrication with grease ISO 51825-K2K-30
Seals :	NBR-O-Rings, 70 Shore
Coatings :	Housing anodized and colour sealed End caps - CED cathodic electrodeposition
Maintenance and inspection :	AMG actuators are free of maintenance within the life time. Provided that: <ul style="list-style-type: none"> • the actuator is properly mounted • the operating medium used is clean and non-aggressive • the actuator is operated under normal ambient conditions • the actuator is used in compliance with the intended use (see assembly and maintenance manual)
Applied standard:	DIN EN ISO 5211, DIN EN 15714-3, VDI / VDE 3845, DIN 79
Options:	Extended angle of rotation 120°, 135°, 180° Adjustable inner / outer travel stops up to +/- 5° via travel-stop-module (BR03C-DE) Ambient temperature up to +100°C (BR03C-HT Version) Ambient temperature down to -40°C (BR03C-TT Version) Sealing elements made of FKM (viton) or alternatively fluorosilicone Tailor made mounting kits and dimensioning acc. To customer requirements Variable cycle times (fast / slow) Variable sens of rotation (clockwise / counterclockwise) Coating options: Hard-Coat, chemical nickelplating, plastic coating, special lacquer



SAF

SAD

Size	42	
Weight [kg]		
Type SAD	34,0	
Type SAF	48,5	
Stroke volume [dm³]		
Type SAD	16,4	
Type SAF	9,5	
Operating times [sec.]¹⁾		
Type SAD OPEN	2,5	
Type SAD CLOSE	2,5	
Type SAF²⁾ OPEN	5,0	
Type SAF²⁾ CLOSE	2,0	

1) operating times at 4,5 bar air pressure supply without load (standard values)

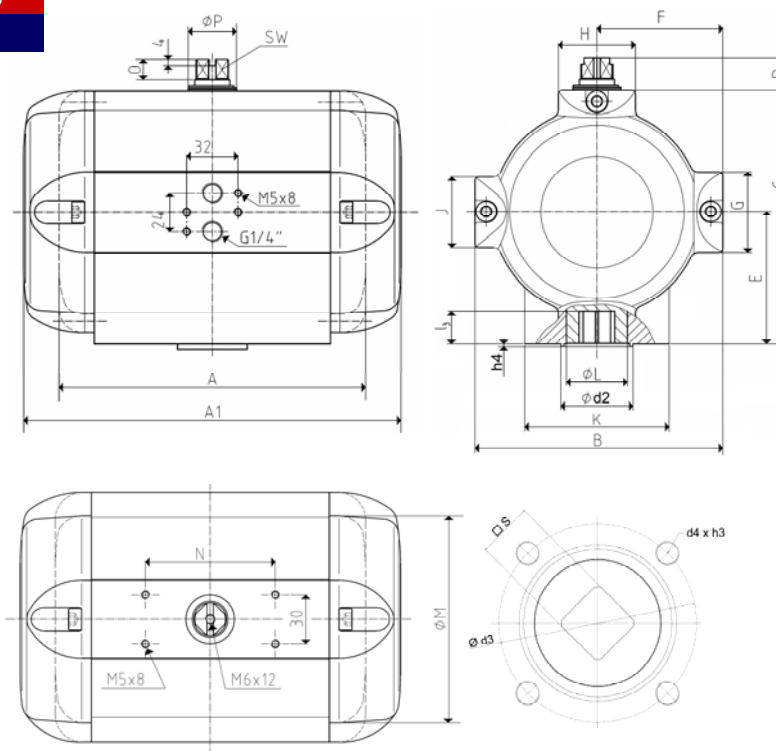
2) Type SAF with 9 springs



Type	number of springs n	spring-torque		air torque Ma [Nm] at operating pressure pe [bar]																											
				Ms [Nm]		2 bar		2,5 bar		3 bar		3,5 bar		4 bar		4,5 bar		5 bar		5,5 bar		6 bar		6,5 bar		7 bar		7,5 bar		8 bar	
		MIN	MAX	MIN	MAX	MIN	MAX	MIN	MAX	MIN	MAX	MIN	MAX	MIN	MAX	MIN	MAX	MIN	MAX	MIN	MAX	MIN	MAX	MIN	MAX	MIN	MAX	MIN	MAX	MIN	MAX
SAD 42	-	-	-	536		694		852		1005		1161		1321		1475		1631		1789		1948		2098		2248		2398			
SAF 42	4	212	352	184	324	342	482	500	640	653	793	809	949	969	1109	1123	1263	1279	1419	1437	1577	1596	1736	1746	1886	1896	2036	2046	2186		
	5	265	440	96	271	254	429	412	587	565	740	721	896	881	1056	1035	1210	1191	1366	1349	1524	1508	1683	1658	1833	1808	1983	1958	2133		
	6	318	528	8	218	166	376	324	534	477	687	633	843	793	1003	947	1157	1103	1313	1261	1471	1420	1630	1570	1780	1720	1930	1870	2080		
	7	371	615			79	323	237	481	390	634	546	790	706	950	860	1104	1016	1260	1174	1418	1333	1577	1483	1727	1633	1877	1783	2027		
	8	424	703					149	428	302	581	458	737	618	897	772	1051	928	1207	1086	1365	1245	1524	1395	1674	1545	1824	1695	1974		
	9	477	791					61	375	214	528	370	684	530	844	684	998	840	1154	998	1312	1157	1471	1307	1621	1457	1771	1607	1921		
	10	530	879							126	475	282	631	442	791	596	945	752	1101	910	1259	1069	1418	1219	1568	1369	1718	1519	1868		
	11	583	967							38	422	194	578	354	738	508	892	664	1048	822	1206	981	1365	1131	1515	1281	1665	1431	1815		
	12	636	1055									106	525	266	685	420	839	576	995	734	1153	893	1312	1043	1462	1193	1612	1343	1762		
	Sonderausführung																														
	13	689	1148								13	472	173	632	327	786	483	942	641	1100	800	1259	950	1409	1100	1559	1250	1709			
	14	742	1231										90	579	244	733	400	889	558	1047	717	1206	867	1356	1017	1506	1167	1656			

Design	SAD / SAF
Size	42
A (double-acting)	362
A1 (single-acting)	550
B	288
C	296
D	20
E	146
F	144
G	60
H	108
K	150
Ø L	80
J	60
Ø M	258
N	80
O	12
Ø P	63
SW	30
Connection ISO 5211	F14
Ø d ₂	100
Ø d ₃	140
d ₄ x h ₃	M16x25
number of bolts	4
h ₄	4
l ₃	40
s	36