

General information

PWS34620220126

The Model 1022 is a low profile single-point load cell designed for direct mounting in low cost weighing platforms. Its small physical size, combined with high accuracy and aluminum construction, makes this low cost load cell ideally suited for retail, bench and counting scales. Using Model 1022 load cells simplifies scale construction, which results in significant parts and labor savings. The Model 1022 is available in a range of capacities: from 3 to 150 kg, approved to OIML R60 (4000d); to 20 to 150 kg, approved to OIML R60 (6000d); to 3 to 100 kg, approved to NTEP (5000d, single). Environmental protection to IP66 is provided as standard. For hazardous environments, ATEX approved versions are available.



Suggested related products

A highly performing weighing system must be accurate, perfectly calibrated and well maintained. In order to improve the load cell performance and to optimize its functioning, you may need the following products:

Weight Transmitter [DAT 1400](#)

Weight Indicator [MCT 1302](#)

Tester 1008 [TESTER 1008](#)

Junction Box [CGS4-C](#)

All indicated data may be changed without notice.
All the measures indicated are expressed in millimeters (mm).

Technical specifications

PWS34620220126

Rated Load (RL):	3, 5, 7, 10, 15, 20, 30, 35, 50, 100, 150, 200 kg
Ultimate overload:	300 % RL
Material:	Aluminium
Degree of protection:	IP66
Accuracy class:	C3, C4
Compensated Temperature:	-10 ÷ +40°C
Temperature range:	-30 ÷ +70°C
Temperature effect on zero balance:	±0.0014 % (NTEP); ±0.010 % (Non Approved); ±0.0023 % (C3); ±0.0014 % (C4) RO/°C
Temperature effect on output:	±0.0010 % (NTEP); ±0.0030 % (Non Approved); ±0.0010 % (C3); ±0.00075 % (C4) RO/°C
Rated output RO:	2 mV/V
Zero balance:	±0.10 mV/V
Insulation resistance:	> 2000 MOhm
Input impedance:	415±15 Ohm
Maximum input voltage:	15 Vdc or Vac rms
Nominal input voltage:	10 Vdc or Vac rms
Cable Length:	0.5 m
Load plan:	350x350
Output impedance:	350±3 Ohm

All indicated data may be changed without notice.
All the measures indicated are expressed in millimeters (mm).

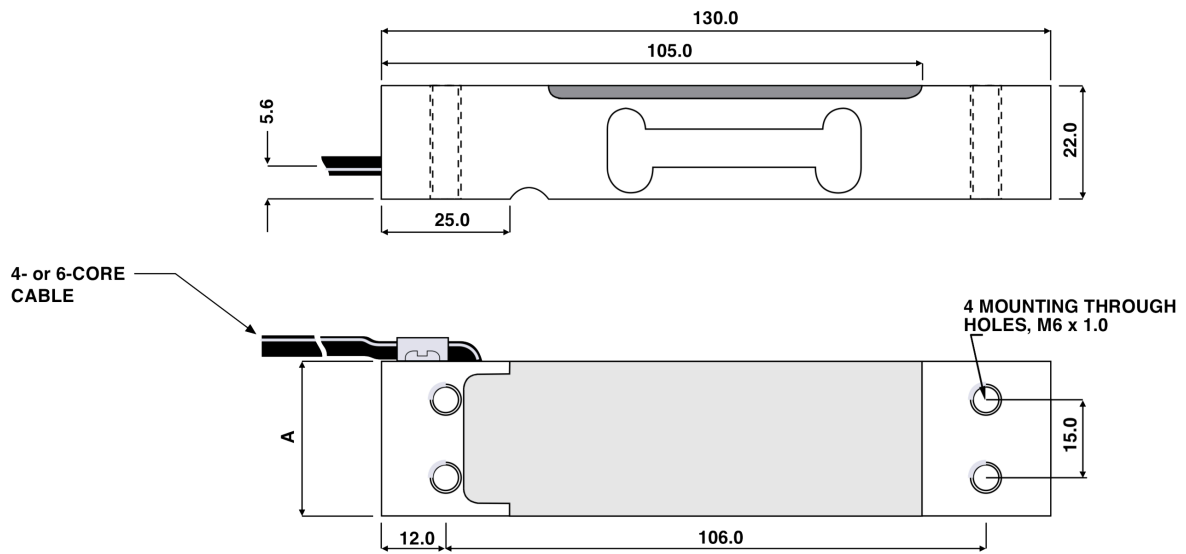
Wiring Schematic Diagram
UNBALANCED BRIDGE CONFIGURATION

+VE INPUT	Green
+VE OUTPUT	Red
-VE INPUT	Black
-VE OUTPUT	White

Balanced bridge available with 6 sense wires

CAPACITY
A

3, 5, 7 kg	25.4
10, 15, 20, 30, 35, 50, 75 kg	30.0
35, 100, 150, 200 kg	40.0

All indicated data may be changed without notice.
 All the measures indicated are expressed in millimeters (mm).