



## **CH WORM GEARED MOTORS AND WORM GEAR UNITS**



## INTRODUCTION

The new CH worm gearboxes of Chiaravalli Group S.p.A. have been produced to satisfy the market that require a product in dimensions and construction without changing the existing drawings and to guarantee non stop of their spare parts.

Chiaravalli Group S.p.A. designed this new product by improving and introducing better technical modifications to offer easier application of the groups to the different assembling configurations so that by offering a better service in flexibility and delivery time.

Starting from these considerations, we have a gearbox with a motor mounting flange that is separable from the housing which incorporate the oil seal; in this way we avoid any risk of damaging the oil seal in case of replacement of the input flange and the O-Ring can be eliminated.

All the aside covers, swinging and with feet, have O-Rings instead of traditional flat gaskets. The sizes 03-04-05 allow the rotation of the feet without disassembling them; furthermore the versions with swinging aside covers allow the lateral flanges to be fitted on both sides with simple fixing screws.

The worm screw has a ZI involute profile: with this worm-wheel coupling we shall get a better performance with a temperature reduction.

The gearboxes and motors are painted with RAL 9022 aluminium colour epoxy powder to protect the parts from oxidation and against micro-blowholes that can come during the pressure of die-castings.

The CHPC pre-stage gears (already present in the catalogue of CHM) can also be mounted with this range, obtaining a gear ratio up to 1:300.

For bigger reductions is possible to have two gears together using an appropriate kit.



## LUBRICATION

All of the groups are supplied with a synthetic lubricant maintenance free and can be mounted in any position. The types of lubricants are described in the table here below.

Lubricant	Ambient	ISO	AGIP	SHELL	IP
°C ambient	-25°C/+50°C	VG 320	Telium VSF 320	Tivela oil S 320	Telium VSF

2D and 3D drawings available on the web site [www.chiaravalli.com](http://www.chiaravalli.com)

Quantity, availability and prices with Chiaravalli B2B



## QUANTITY OF OIL IN LITRES

CH	03	04	05	06	07	08
	0.040	0.060	0.10	0.38	0.52	0.73



## MOTOR MOUNTING FLANGES

Gears supplied with mounting flanges must be assembled with motors whose shaft and flange tolerances correspond to a "normal" class of quality in order to avoid vibration and forcing of the input bearing. Motors supplied by Chiaravalli Group S.p.A. guarantee this requirement fulfilled. For ease of consultation, the correspondence of the size of the B5 and B14 motor with the sizes of the shaft and the motor connection flange are shown in the following table.

Remember that, as the motor connection flanges are separate from the body it is also possible to have a shaft / flange combination that does not correspond to the table, e.g. 19/140, thereby offering adaptability for other non-unified models such as the brushless or direct current types.

MMF	056	063	071	080	090	100	112
B5	9/120	11/140	14/160	19/200	24/200	28/250	28/250
B14	9/80	11/90	14/105	19/120	24/140	28/160	28/160



## NEW MODEL





# CH 03/04/05 WORM GEARED MOTORS AND WORM GEAR UNITS

CH...

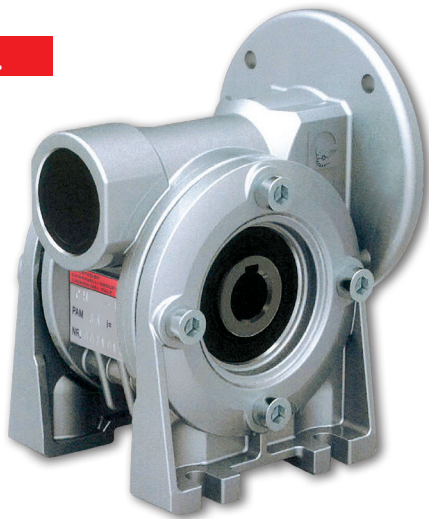

CH...P



CHE...P

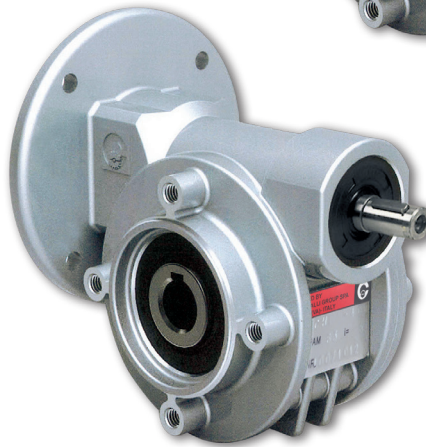

CHE...

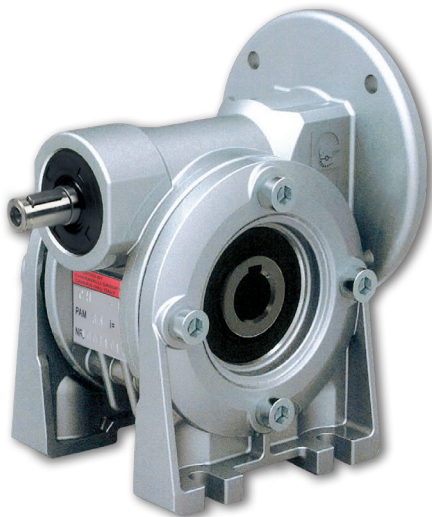

CHR...P

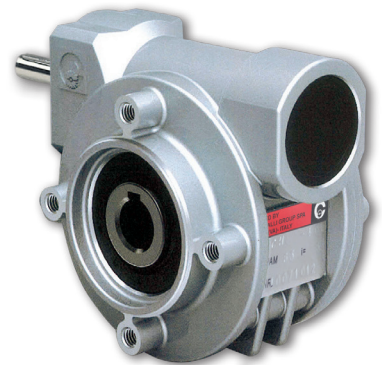

CHR...

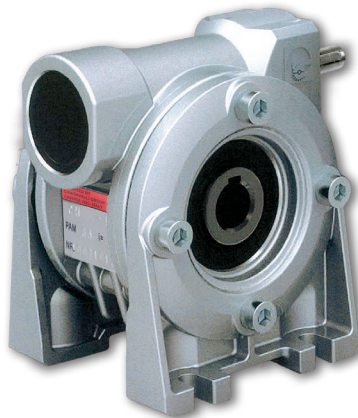

CHRE...

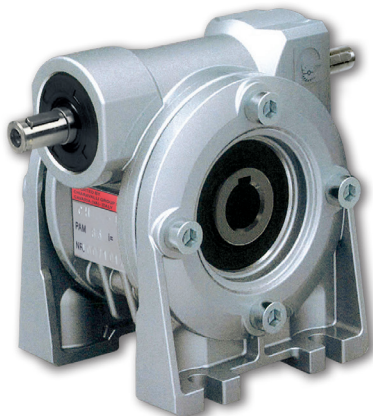

CHRE...P

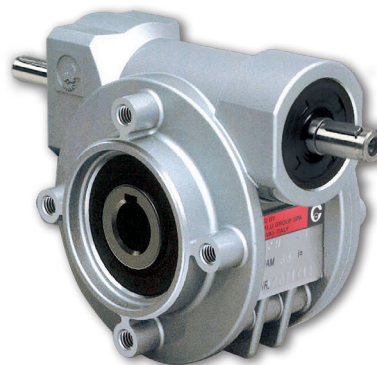



# CH - CH...P 03/04/05 DESIGNATION

TYPE (1)	SIZE	VERSION	FLANGE POS. (2)	i	M.M.F.	MOUNT. POS.
CH	03	A	1	RATIO SEE PAGE 64	63B5	UNIVERSALE
CH..P		P	2		63B14	
CHR		PF			56B5	
CHR..P		N			56B14	
CHE		V				
CHE..P						
CHRE						
CHRE..P						

TYPE (1)	SIZE	VERSION	FLANGE POS. (2)	i	M.M.F.	MOUNT. POS.
CH	04	A	1	RATIO SEE PAGE 65	71B5	UNIVERSALE
CH..P		P	2		71B14	
CHR		PF			63B5	
CHR..P		PFA			63B14	
CHE		N				
CHE..P		V				
CHRE						
CHRE..P						

TYPE (1)	SIZE	VERSION	FLANGE POS. (2)	i	M.M.F.	MOUNT. POS.
CH	05	A	1	RATIO SEE PAGE 66	80B5	UNIVERSALE
CH..P		P	2		80B14	
CHR		PF			71B5	
CHR..P		PFA			71B14	
CHE		N			63B5	
CHE..P		V			63B14	
CHRE						
CHRE..P						



## ORDER EXAMPLE

CH	04P	FA	2	35	63 B14
CH	04			10	71 B5

If the motor is also required, please specify:

Size es. 63 C4  
 Power es. Kw 0.22  
 Poles es. 4  
 Voltage es. V230/400  
 Frequency es. 50 Hz  
 Flange es. B14

N.B. Gear box required with output flanges F or FA must be ordered PF or PFA version.

1) see page 61  
 2) see page 63

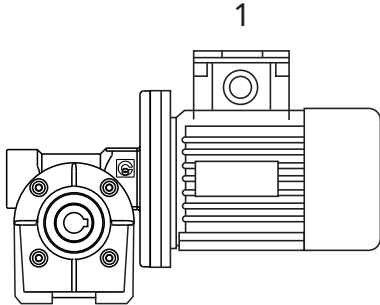
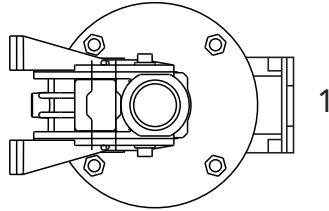
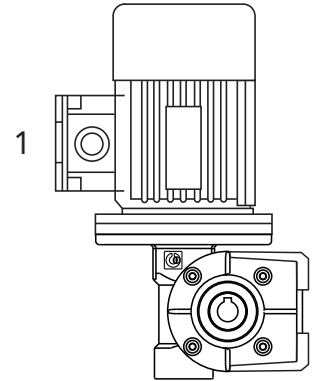
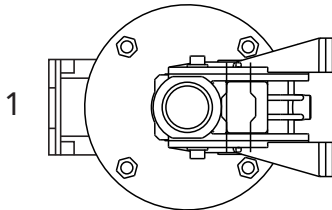
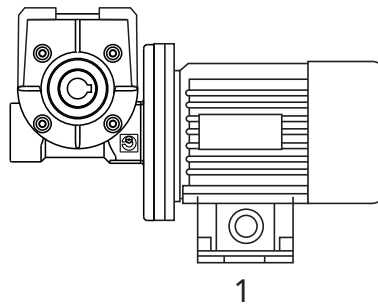
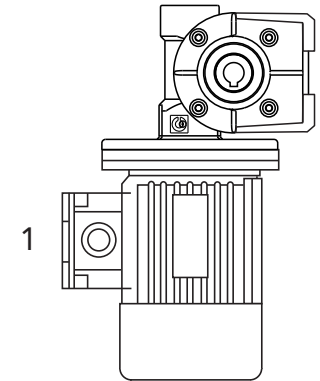
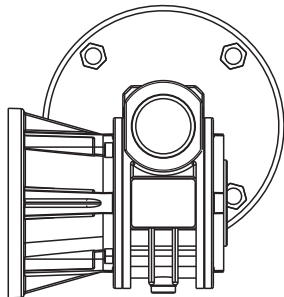
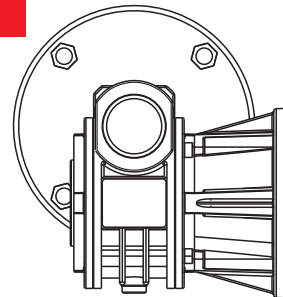
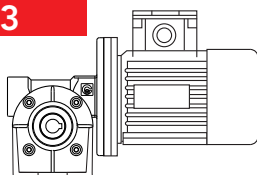
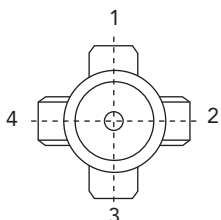
**B3****B6****V5****B7****B8****V6****PF1****PF2****B3****TERMINAL BOX POSITION**

N.B. The position of the terminal box always refers to the B3 position.



# CH 03 - PERFORMANCE WITH 4-POLE MOTORS 1400 REVS. INPUT

TYPE	i=ratio	n2 r/min	Kw=P1	Nm=T2	f.s.	Possible types of motor connections	
CH 03	7	200	0.22	8	1.8	63/56	B5/B14
	10	140	0.22	11	1.4	63/56	B5/B14
	15	93	0.22	16	1.0	63/56	B5/B14
	20	70	0.22	20	0.9	63/56	B5/B14
	30	47	0.18	22	0.8	63/56	B5/B14
	40	35	0.12	18	1.0	63/56	B5/B14
	60	23	0.09	18	1.0	63/56	B5/B14
	70	20	0.09	15	0.9	56	B5/B14

Weight Kg 1

## DIMENSIONS

**A**

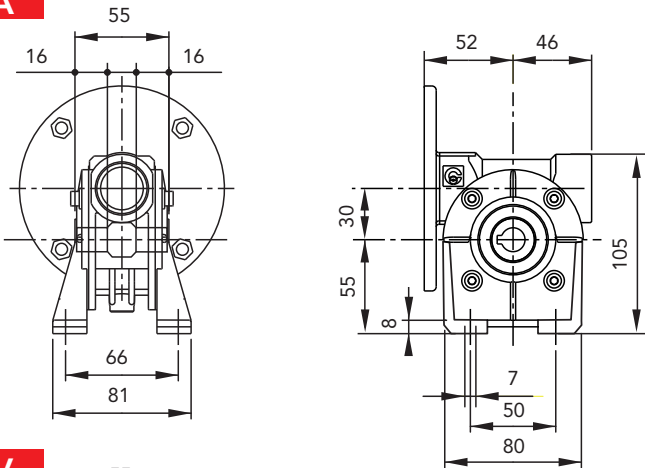

**P**

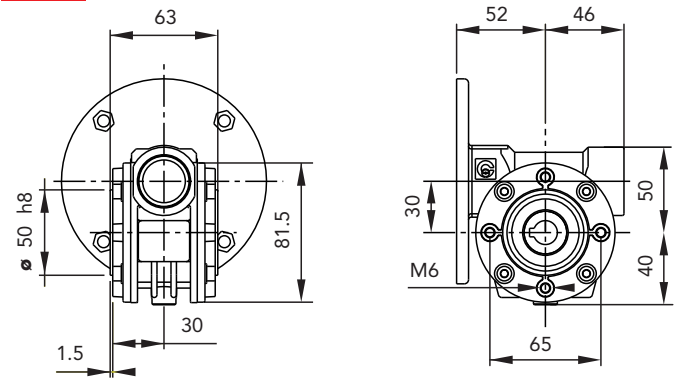

**V**

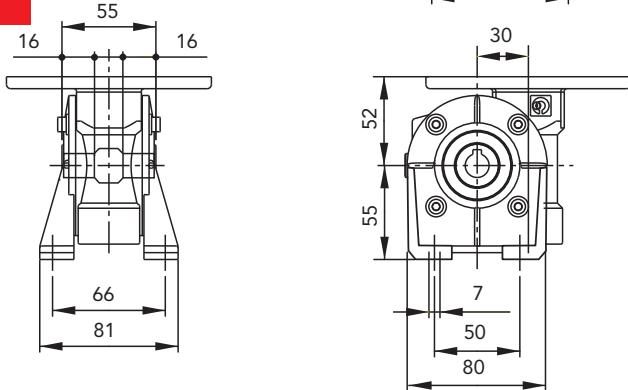

**PF1**

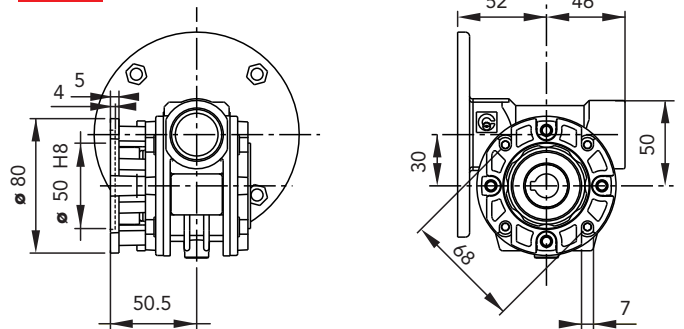

**N**

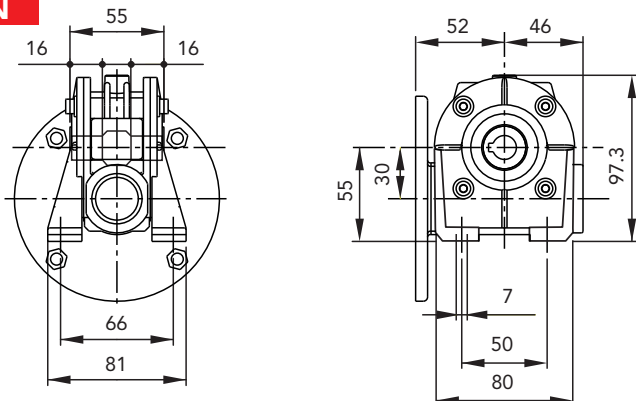



# CH 04 - PERFORMANCE WITH 4-POLE MOTORS 1400 REVS. INPUT

TYPE	i=ratio	n2 r/min	Kw=P1	Nm=T2	f.s.	Possible types of motor connections	
CH 04	7	200	0.55*	22	1.4	71/63	B5/B14
	10	140	0.55*	30	1.0	71/63	B5/B14
	14	100	0.37	29	1.0	71/63	B5/B14
	20	70	0.37	38	1.0	71/63	B5/B14
	28	50	0.37	40	0.9	71/63	B5/B14
	35	40	0.25	41	0.9	71/63	B5/B14
	46	30	0.18	37	1.0	63	B5/B14
	60	23	0.18	37	0.9	63	B5/B14
	70	20	0.12	33	0.9	63	B5/B14
	100	14	0.12	30	0.9	63	B5/B14

\* Motors 71 gr.

Weight Kg 2,1

## DIMENSIONS

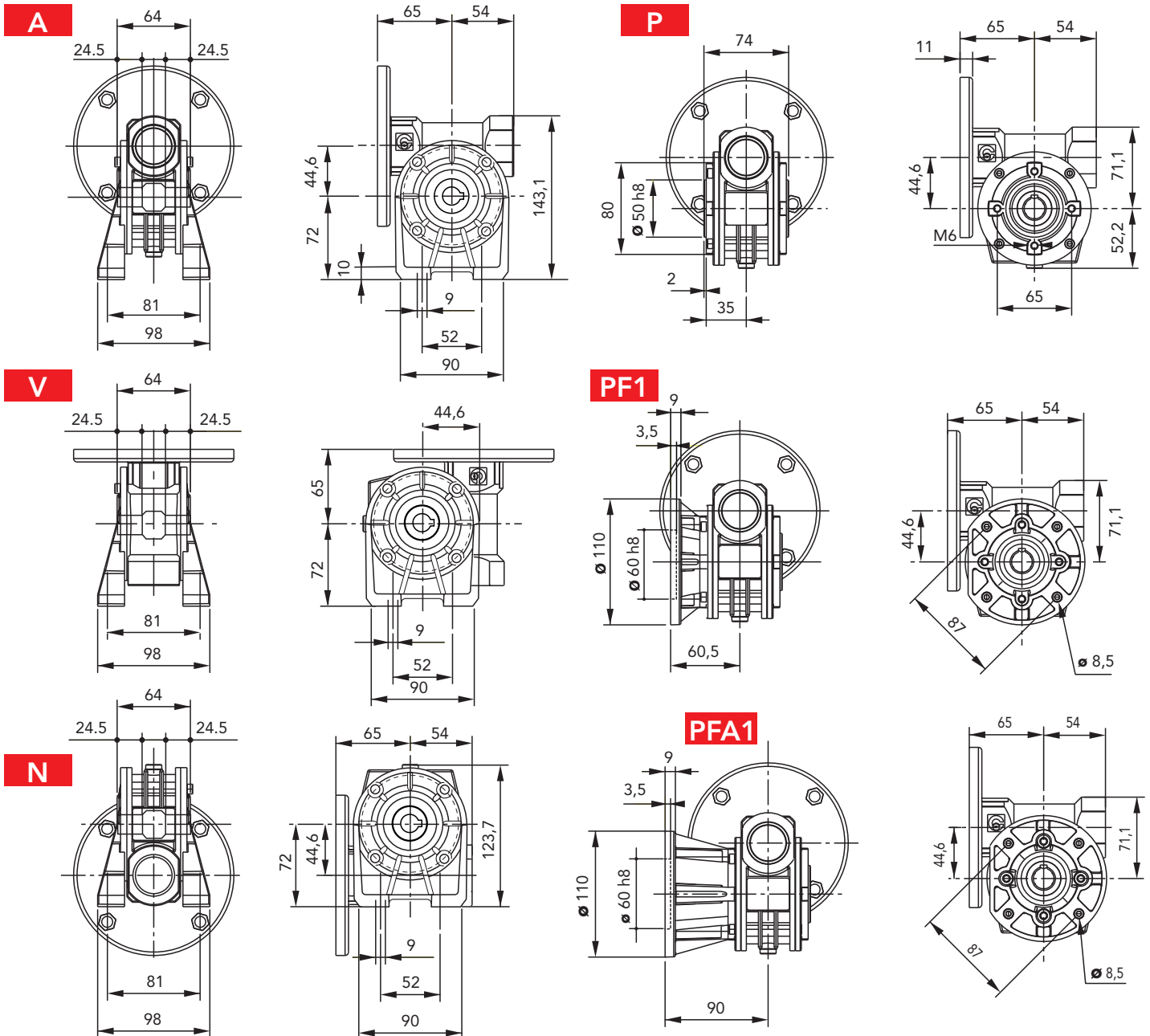





# CH 05 - PERFORMANCE WITH 4-POLE MOTORS 1400 REVS. INPUT

TYPE	i=ratio	n2 r/min	Kw=P1	Nm=T2	f.s.	Possible types of motor connections	
CH 05	7	200	1.1*	40	1.4	80/71	B5/B14
	10	140	1.1*	49	1.2	80/71	B5/B14
	14	100	0.75	57	1.1	80/71	B5/B14
	18	78	0.55	52	1.1	80/71	B5/B14
	24	58	0.55	67	0.9	80/71	B5/B14
	28	50	0.55	73	1.0	80/71	B5/B14
	36	39	0.37	61	1.1	71	B5/B14
	45	31	0.37	65	0.9	71/63	B5/B14
	60	23	0.25	60	1.0	71/63	B5/B14
	70	20	0.22	55	0.9	63	B5/B14
	80	17	0.18	54	1.0	63	B5/B14
	100	14	0.18	50	0.9	63	B5/B14

\* Motors 80 gr.

Weight Kg 3

## DIMENSIONS

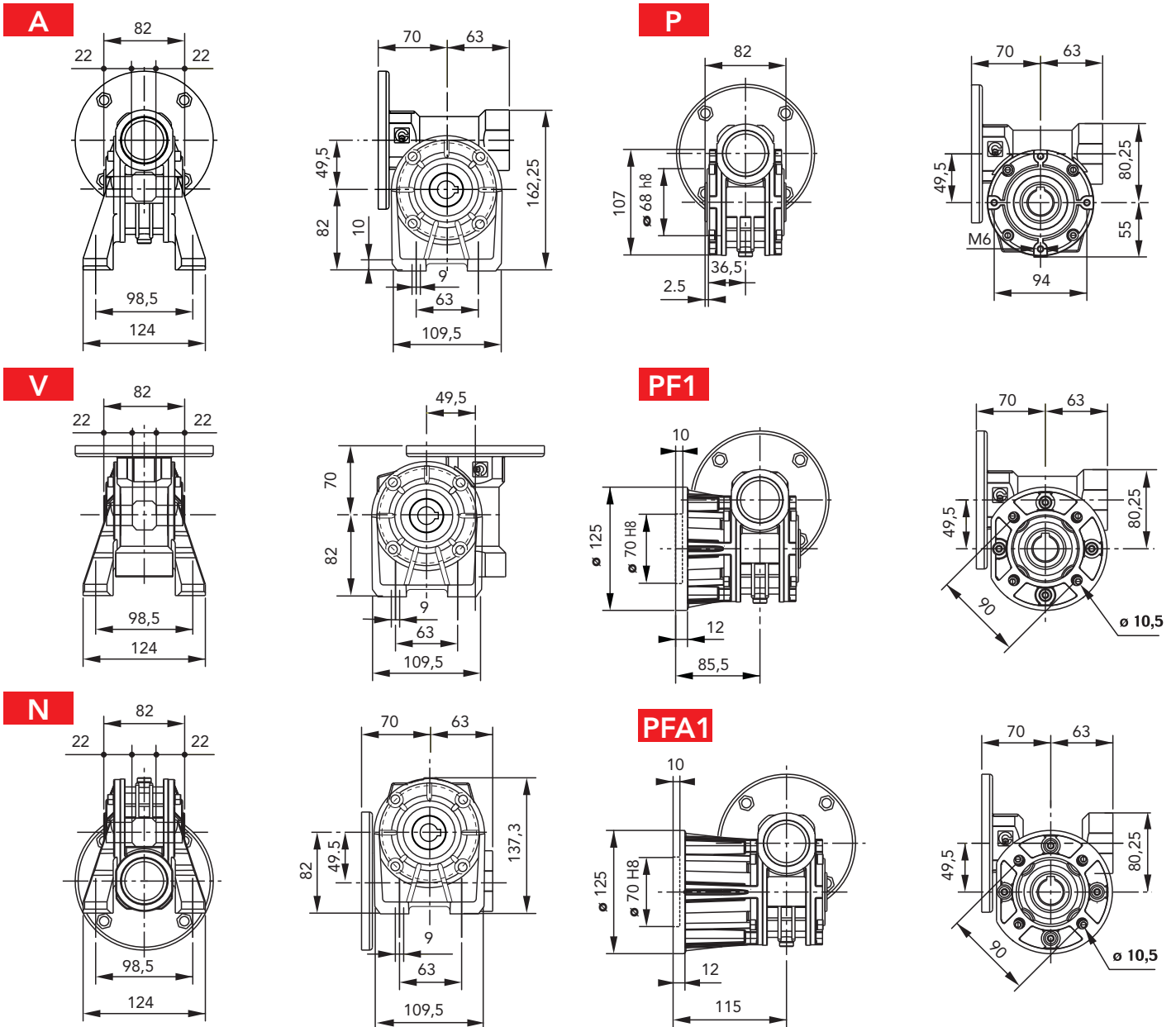

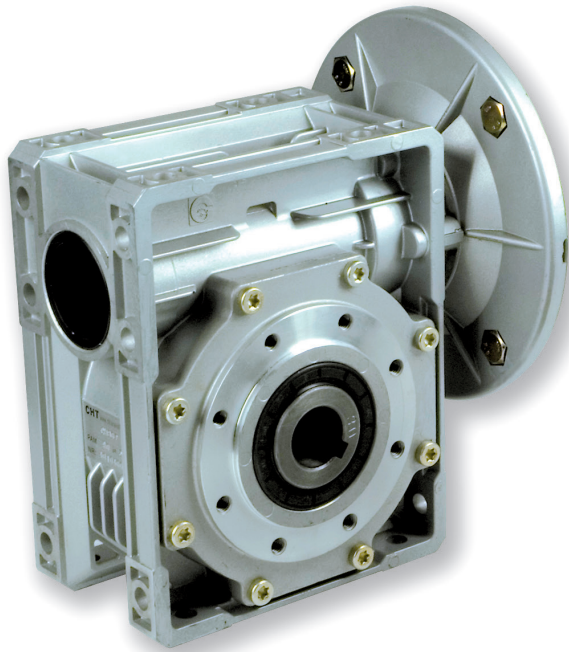

CH..

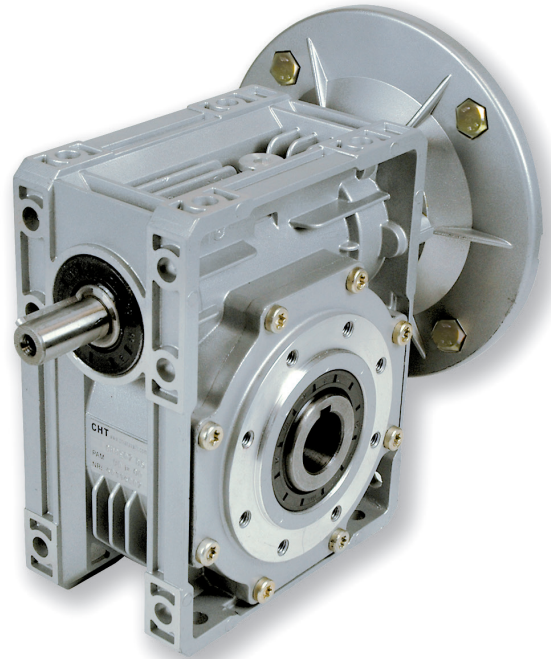

CHE..

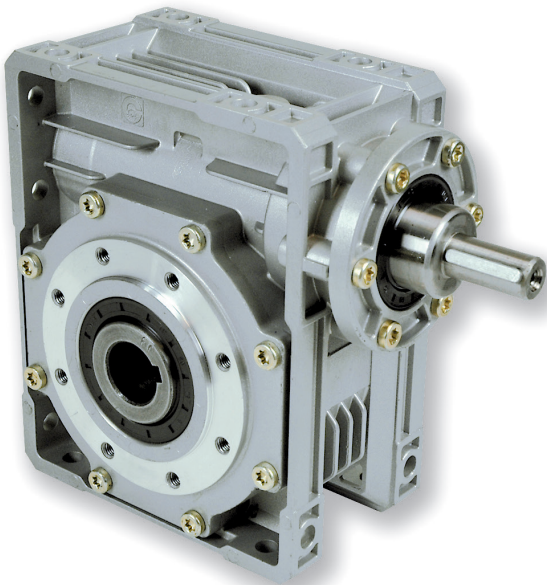

CHR..

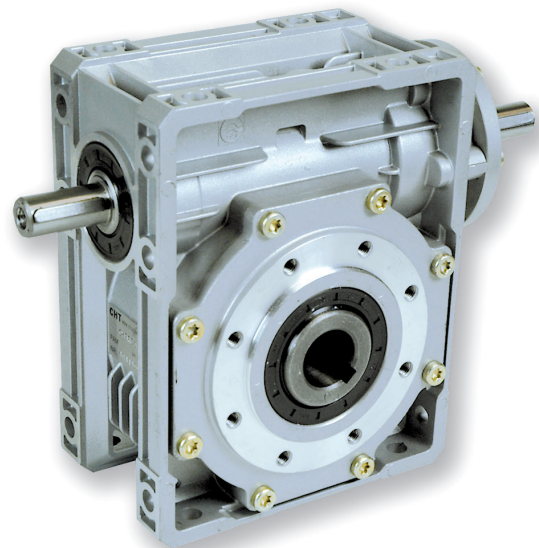

CHRE..



## CH 06/07/08 DESIGNATION

TYPE (1)	SIZE	VERSION	FLANGE POS. (2)	i	M.M.F.	MOUNT. POS.
CH	06	FC	1	RATIO SEE PAGE 70-71-72	100B5	UNIVERSALE
CHR	07	F	2		100B14	
CHE	08	(3)			90B5	
CHRE					90B14	
					80B5	
				80B14		
				71B5		
				71B14		



## ORDER EXAMPLE

CH	06	FC	1	19	90 B5
----	----	----	---	----	-------

If the motor is also required, please specify:

Size es. 90 L4  
 Power es. Kw 1.5  
 Poles es. 4  
 Voltage es. V230/400  
 Frequency es. 50 Hz  
 Flange es. B5

- 
- 1) see page 67
  - 2) see page 69
  - 3) lack of instructions indicates that the gear is not equipped with an output flange



# MOUNTING POSITION

**B3**

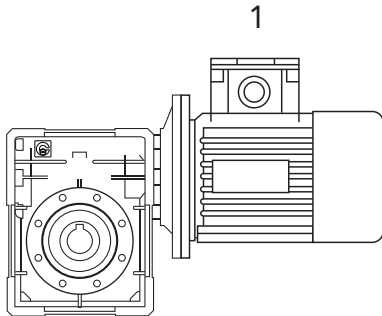

**B6**

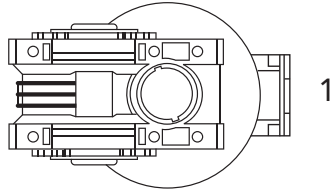

**V5**

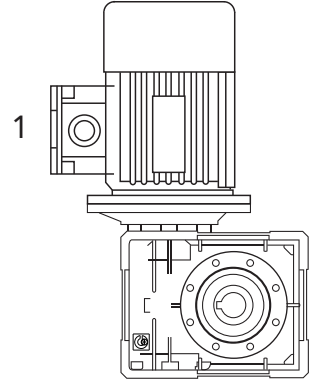

**B7**

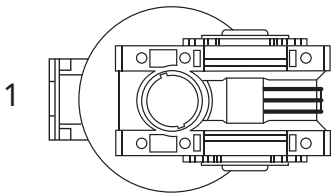

**B8**

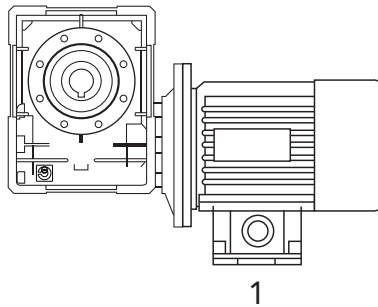

**V6**

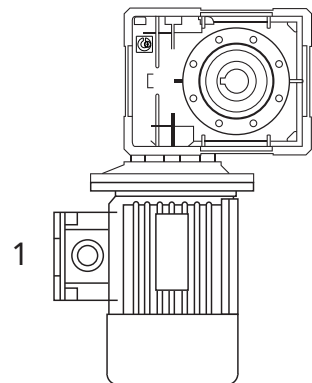

**F1**

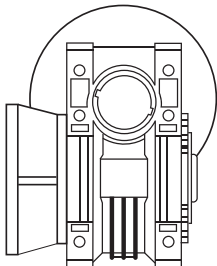

**F2**

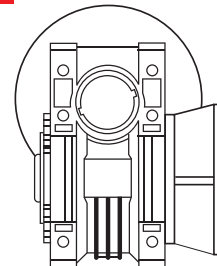

**B3**

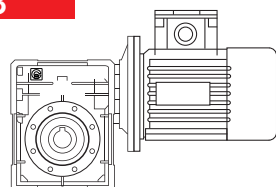
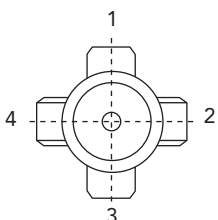

## TERMINAL BOX POSITION

N.B. The position of the terminal box always refers to the B3 position.



# CH 06 - PERFORMANCE WITH 4-POLE MOTORS 1400 REVS. INPUT

TYPE	i=ratio	n2 r/min	Kw=P1	Nm=T2	f.s.	Possible types of motor connections	
CH 06	7	200	1.85	75	1.5	90/80	B5/B14
	10	140	1.85	105	1.3	90/80	B5/B14
	12	117	1.85	129	1.1	90/80	B5/B14
	15	93	1.85	146	1.0	90/80	B5/B14
	19	74	1.50	150	1.0	90/80	B5/B14
	24	58	1.10	138	1.1	90/80	B5/B14
	30	47	1.10	155	1.0	90/80	B5/B14
	38	37	0.75	133	1.1	90/80	B5/B14
	45	31	0.75	152	0.9	80/71	B5/B14
	64	22	0.37	101	1.2	80/71	B5/B14
80	17	0.37	112	1.0	71	B5/B14	
100	14	0.37	110	1.0	71	B5/B14	

Weight Kg 5,2

## DIMENSIONS

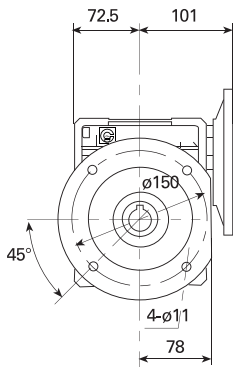
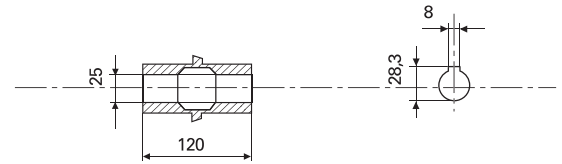
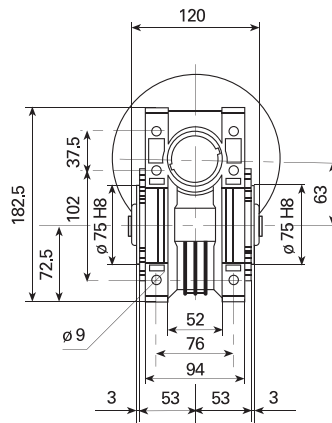
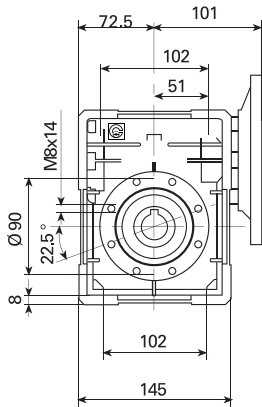

CH06FC 1

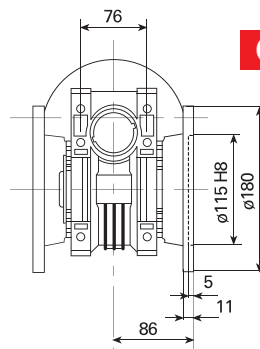

CH06FC 2

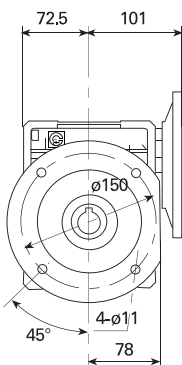

CH06F1

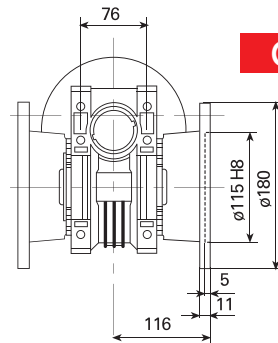

CH06F2



# CH 07 - PERFORMANCE WITH 4-POLE MOTORS 1400 REVS. INPUT

TYPE	i=ratio	n2 r/min	Kw=P1	Nm=T2	f.s.	Possible types of motor connections	
CH 07	7	200	4	170	1.1	100/90	B5/B14
	10	140	3	175	1.3	100/90	B5/B14
	15	93	3	250	1.0	100/90	B5/B14
	20	70	2.20	240	1.0	100/90	B5/B14
	25	56	1.85	250	1.0	90/80	B5/B14
	30	47	1.50	230	1.2	90/80	B5/B14
	40	35	1.1	215	1.2	90/80	B5/B14
	50	28	1.1	220	0.9	90/80	B5/B14
	60	23	0.75	200	1.0	90/80	B5/B14
	80	17	0.55	180	1.0	80/71	B5/B14 *
100	14	0.37	140	1.1	80/71	B5/B14 *	

\*71 solo B5

Weight Kg 9,2

## DIMENSIONS

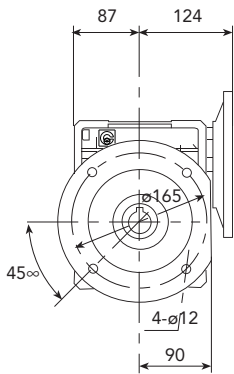
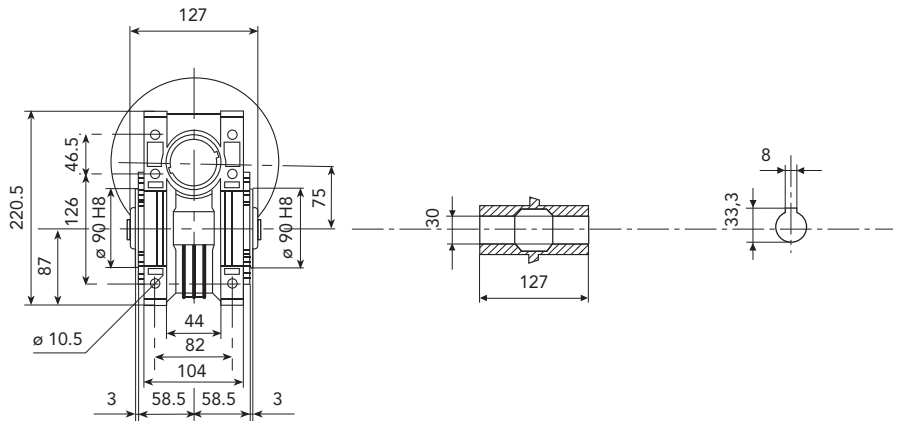
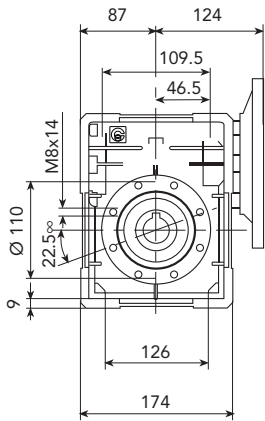

CH07FC 1

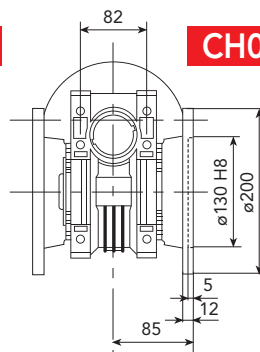

CH07FC 2

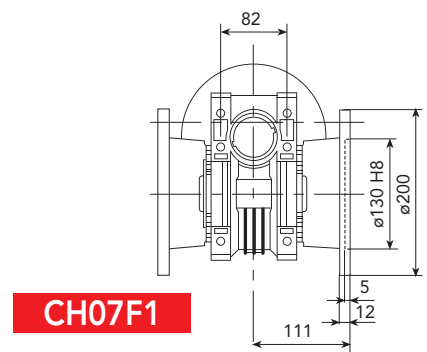

CH07F1

CH07F2

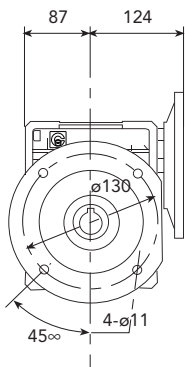

CH07FE1

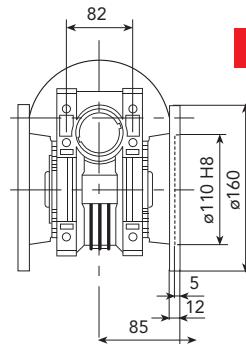

CH07FE2



# CH 08 - PERFORMANCE WITH 4-POLE MOTORS 1400 REVS. INPUT

TYPE	i=ratio	n2 r/min	Kw=P1	Nm=T2	f.s.	Possible types of motor connections	
CH 08	7	200	4	170	1.5	112/100/90	B5/B14
	10	140	4	240	1.2	112/100/90	B5/B14
	15	93	4	350	0.9	112/100/90	B5/B14
	20	70	3.00	340	0.9	100/90	B5/B14
	23	61	2.20	280	1.1	100/90	B5/B14
	30	47	2.20	340	1.1	100/90	B5/B14
	40	35	1.85	340	0.9	90/80	B5/B14
	46	30	1.5	340	1.0	90/80	B5/B14
	56	25	1.1	290	1.0	90/80	B5/B14
	64	22	1.1	290	0.9	90/80	B5/B14
	80	17	0.75	260	1.0	90/80	B5/B14
	100	14	0.55	220	1.0	80	B5/B14

Weight Kg 12,2

## DIMENSIONS

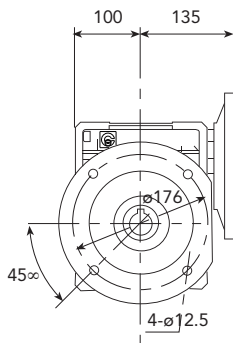
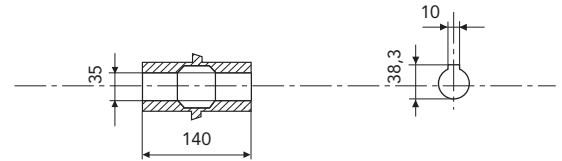
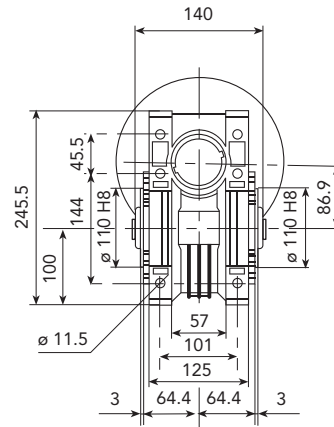
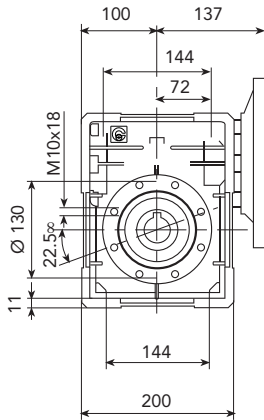

CH08FC 1

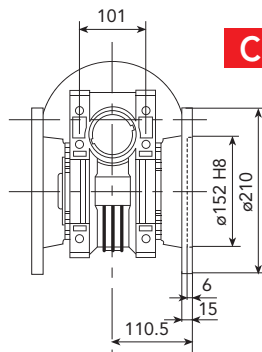

CH08FC 2

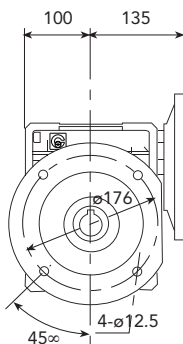

CH08F1

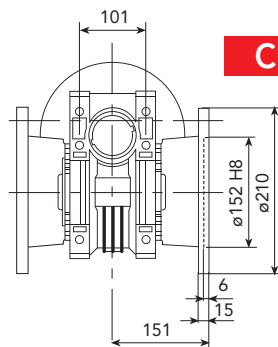

CH08F2